

BVH2/BVH3

Internally threaded 2- and 3-way ball valves

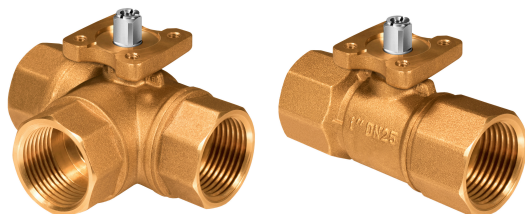

Valves designed for control of hot, cold or glycol-mixed water in heating and ventilation systems. The valves are intended for use together with our SEB4/SEB5 actuators or with our damper actuators (if using an adaptor).

- Size DN15...DN50
- Kvs value 4...63
- Media temperature -5...+120°C
- Pressure rating PN20
- Rangeability 100:1
- High close-off pressures

Function

2-way valve

On top of the valve stem, there is a groove to indicate closing direction.

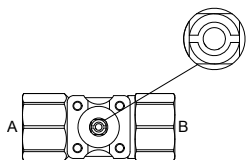

Fig.1. 2-way valve 100% open between port A and port B.

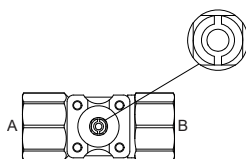

Fig.2. 2-way valve closed completely.

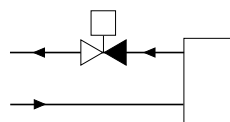

Fig.3. 2-way valve .

3-way valve

On top of the valve stem, there is a T-shaped groove to indicate closing and opening direction. The T-shape corresponds to the hole in the valve ball. Normal function for a characterized (flow plate installed on port A) mixing valve is that the 3-way valve is closed between port A and port C (the ports opposite each other) when the stem is in this position.

In this position, the valve is also 100% open between port B and the common supply port C (fig. 4).

When the stem is in the position as seen in fig.4, the 3-way valve is 100% open between port A and port C and consequently completely closed between the bottom port B and the common port C.

MAIN OFFICE BRESSANONE

I-39042 Bressanone (BZ) tel: +39 0472 830626
via Julius-Durst-Str. 50 fax: +39 0472 831840
VAT No. IT02748450216 www.industrietechnik.it

BVH2/BVH3

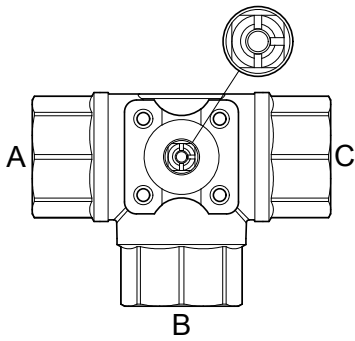

Fig.4. 3-way valve 100% open between port B and port C.

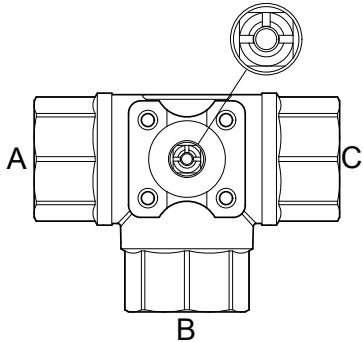

Fig.5. 3-way valve 100% open between port A and port C.

Fig.6. 3-way valve

You can also use the 3-way valves as diverting valves with functions as seen in the 3 scenarios below. The left and right pictures correspond to the 90° opening angle of the actuator.

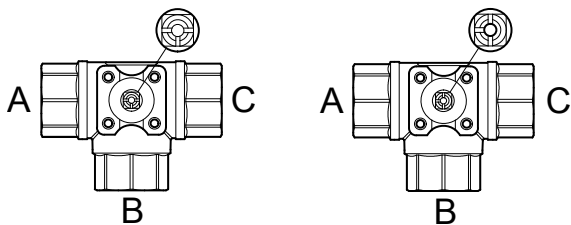

Fig.7. In the left picture the flow path is opened in all directions. In the right picture the flow path between port A and port B is open, while it is closed in port C.

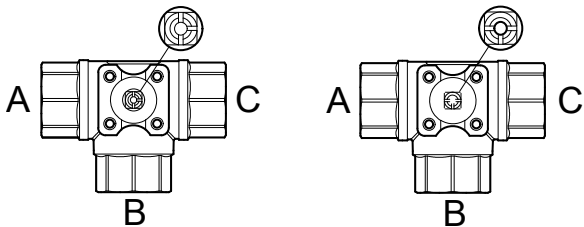

Fig.8. In the left picture the flow path between port B and port C is open while closed in port A. In the right picture the flow path is open in all directions.

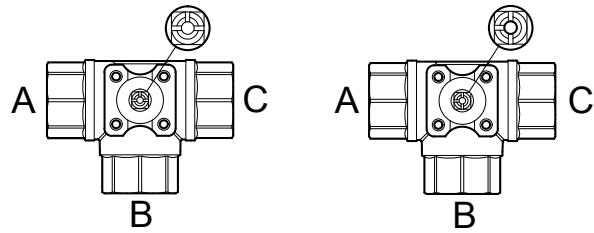

Fig.9. In the left picture there is an open flow path between port A and port C while port B is closed. In the right picture the flow path between port A and port B is open, while it is closed in port C.

Installation

The 2- way valve should be mounted with port A on the inlet and port B on the return (flow direction A in, B out) to ensure that the ball closes tightly and to prevent any noise when closing.

When used as a mixer the 3- way valve must be mounted in correspondence with the mixing point.

- Before installation of the control valve, ensure that the pipe is clean. Make sure that pipe scale, metal chips, welding slag and other foreign materials are removed.
- Make sure there is ample space above the valve to facilitate easy removal of the valve actuator
- The valve should never be mounted at an angle of more than 90°.

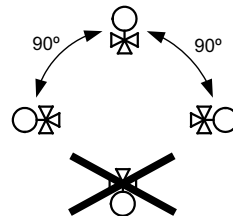

Fit a strainer/filter upstream of the valve to prolong the equipment's life span.

Technical data

Application	Heating systems, cooling systems, ventilation systems
Pressure rating	PN20
Connection	BSP internally threaded according to UNI EN 10226-1
Flow characteristics	2-way: A - B = equal percentage; 3-way: A - C = equal percentage, B - C = linear
Max. leakage	0% of Kvs
Media	Hot water, cold water, glycol-mixed water (max. 50% glycol)
Media temperature	-5...120°C
Rangeability	100:1
Stroke	90°



This product carries the CE-mark. More information is available at www.industrietechnik.it

Material

Body	Brass CW611N
Ball	Chromed brass CW611N
Flow plate	POM
Circlips	Stainless steel 1.4310
Stem	Stainless steel 1.4305
Seat	PTFE
O-rings	EPDM

2-way valves

Article	Nominal diameter	Kvs between port A - B
BVH215B	DN15	4.0
BVH220B	DN20	6.3
BVH225A	DN25	10
BVH232A	DN32	16
BVH240A	DN40	25
BVH250A	DN50	40
BVH250B	DN50	63

3-way valves

Article	Nominal diameter	Kvs between port A - C	Kvs between port B - C
BVH315B	DN15	4.0	2.5
BVH320B	DN20	6.3	4.0
BVH325A	DN25	10	6.3
BVH332A	DN32	16	10
BVH340A	DN40	25	16
BVH350A	DN50	40	25
BVH350B	DN50	63	31.5

MAIN OFFICE BRESSANONE

I-39042 Bressanone (BZ) tel: +39 0472 830626
 via Julius-Durst-Str. 50 fax: +39 0472 831840
 VAT No. IT02748450216 www.industrietechnik.it

BVH2/BVH3

3 (6)



Accessories

Article	Description
BVS	Coupling adapter with damper actuators without spring return from 4 to 24 Nm
BVM	Coupling adapter with 5 Nm damper actuators with spring return

Combination options (valves and actuators) and max diff. pressure

Article	ΔP_s^1 SEB4..., 4 Nm DAN../DMN..., 4 Nm DAN../DMN..F, 5 Nm [kPa]	ΔP_{max}^2 SEB4..., 4 Nm DAN../DMN..., 4 Nm DAN../DMN..F, 5 Nm [kPa]	ΔP_s^1 SEB5..., 5 Nm DAS../DMS..., 8 Nm DAN../DMN..F, 5 Nm [kPa]	ΔP_{max}^2 SEB5..., 5 Nm DAS../DMS..., 8 Nm DAN../DMN..F, 5 Nm [kPa]
BVH215B	660	350	N/D	N/D
BVH220B	660	350	N/D	N/D
BVH225A	660	350	N/D	N/D
BVH232A	N/D	N/D	580	350
BVH240A	N/D	N/D	580	350
BVH250A	N/D	N/D	580	350
BVH250B	N/D	N/D	580	350
BVH315B	660	350	N/D	N/D
BVH320B	660	350	N/D	N/D
BVH325	660	350	N/A	N/A
BVH332A	N/D	N/D	580	350
BVH340A	N/D	N/D	580	350
BVH350B	N/D	N/D	580	350

ΔP_s constitutes the max. permitted differential pressure at which the valve actuator can safely close against the pressure.

ΔP_{max} constitutes the max. permitted differential pressure over the flow path of the valve for the entire actuating range of the actuator (i.e. open valve).

Pressure drop curves

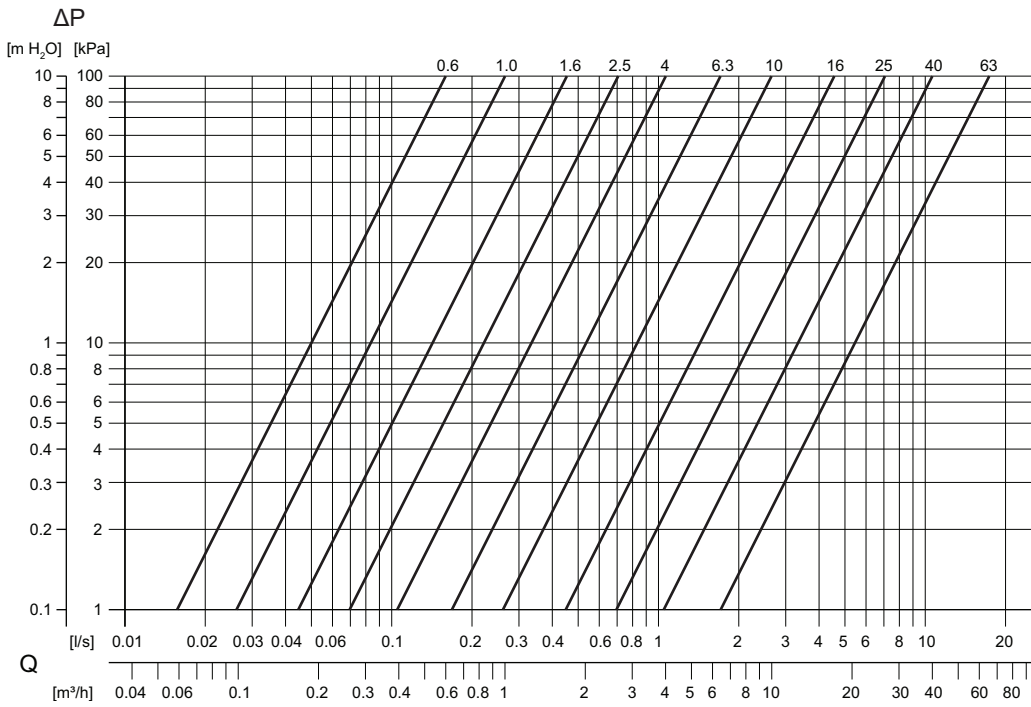

ΔP = Pressure drop

Q = Flow

Example, pressure drop curves

If the pressure drop is 40 kPa (A) and the flow is 4 m³/h (B), a valve with the Kvs value 6.3 (C) is preferably selected. See the markings in the picture below.

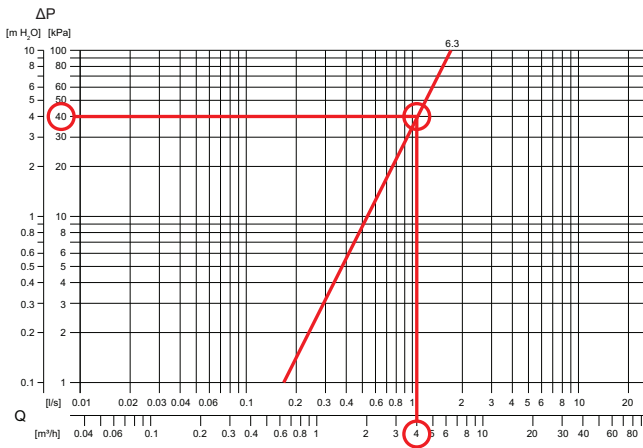

MAIN OFFICE BRESSANONE

I-39042 Bressanone (BZ) tel: +39 0472 830626
 via Julius-Durst-Str. 50 fax: +39 0472 831840
 VAT No. IT02748450216 www.industrietechnik.it

BVH2/BVH3

Dimensions

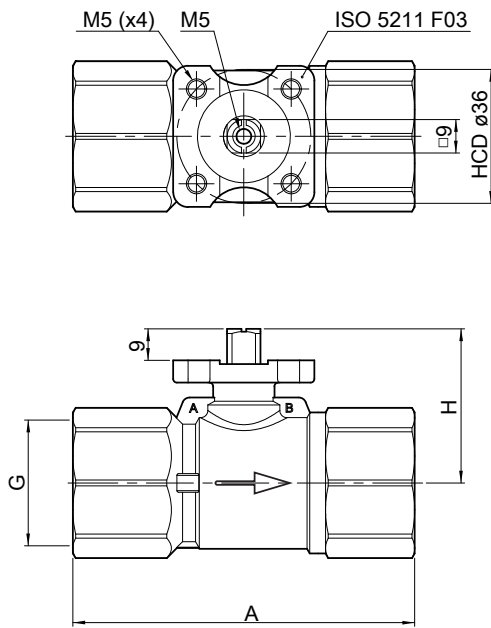

Fig. 10- 2- way valve

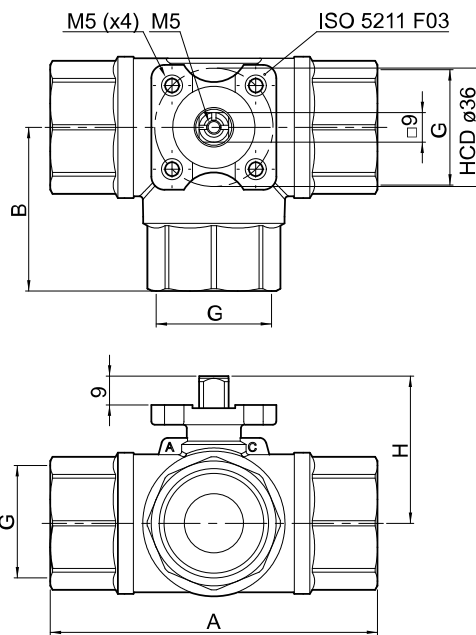

Fig.11- 3- way valve

Article	A	B	H	G(*)
BVH215B	60	N/D	40	Rp 1/2
BVH220B	68	N/D	45	Rp 3/4
BVH225A	89	N/D	46	Rp 1
BVH232A	103	N/D	53	Rp 1 1/4
BVH240A	113	N/D	56	Rp 1 1/2
BVH250A	127	N/D	62	Rp 2
BVH250B	127	N/D	62	Rp 2
BVH315B	61	31	38.5	Rp 1/2
BVH320B	67	32	45	Rp 3/4
BVH325A	89	47	46	Rp 1
BVH332A	99	50	52	Rp 1 1/4
BVH340A	106	52	56	Rp 1 1/2
BVH350A	123	71	64	Rp 2
BVH350B	123	71	64	Rp 2

[mm], unless otherwise specified. (*) According EN UNI 10226-1

Documentation

All documentation can be downloaded from www.industrietechnik.it.

MAIN OFFICE BRESSANONE

I-39042 Bressanone (BZ) tel: +39 0472 830626
 via Julius-Durst-Str. 50 fax: +39 0472 831840
 VAT No. IT02748450216 www.industrietechnik.it

BVH2/BVH3

6 (6)

 industrie
 technik®