



SPRING RETURN DAMPER ACTUATORS (10 Nm)

DATxF, DMTxFs

FUNCTION

On/Off or modulating spring return damper control. The actuator opens the damper loading the return spring; with current cut-off the spring moves the damper in a safe position.

APPLICATIONS

Well-suited for applications with security dampers used as antifreeze, antismoke or for sealing in the hygienic-sanitary field.

TYPE	POWER SUPPLY	SIGNAL CONTROL	AUXILIARY SWITCHES
DAT24F	24 V AC/DC	On/Off	-
DAT24FS	24 V AC/DC	On/Off	2
DMT24FS	24 V AC/DC	Modulating	2
DAT230F	230 V AC	On/Off	-
DAT230FS	230 V AC	On/Off	2

Actuator	DAT24F	DMT24FS	DAT230F
Damper area (*)		2.0 m ²	
Torque		10 Nm	
Power supply	24 V AC/DC	24 V AC/DC	230 V AC
Frequency		50...60 Hz	
Power consumption			
- operating		5.0 W	
- at the end stops		2.5 W	
For wire sizing	10 VA	7 VA	10 VA
Connection motor	1 m, 2 x 0.75 mm ²	1 m, 4 x 0.5 mm ²	1 m, 2 x 0.75 mm ²
Connection auxiliary switches (suffix S in part number)		1 m, 6 x 0.5 mm ²	
Aux. switches rating (2 x SPDT) (suffix S in part number)		3(1.5) A 250 V AC	
Running time			
- motor	≤100 s	≤130 s	≤100 s
- spring back		≤ 20 s	
Noise level		50 dB motor, 62 dB spring	
Weight		2400 g	
Control signal	On/Off	0...10 V DC	On/Off
Rotation angle			
- operating		0...90° (max 93° mechanical)	
- limitation		5...85° in 5° steps	
Direction of rotation		bidirectional	
Protection class	III	III	II
Degree of protection		IP54	
Room temperature		-30...+50°C	
Room humidity		5...95% r.h.	
Maintenance		free	
Standards		CE	

(*) the indication of the damper area is not significant, the data that must be taken into account is the value of the torque in Nm.

SPRING RETURN DAMPER ACTUATORS (10 Nm)

DATxF, DMTxFs

Direction of rotation setting

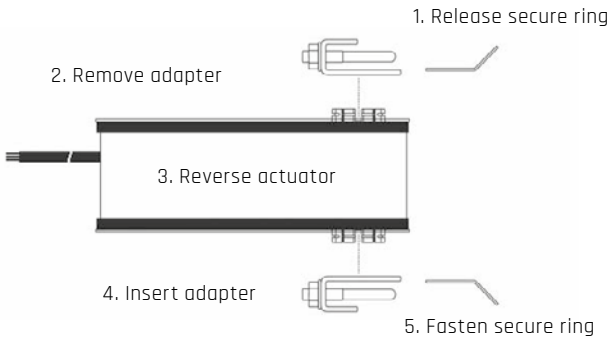

Limitation of rotation angle

For 5° to 45° (see fig. 1)

1. Loosen screw of the mechanical limiter plate.
2. Move the limiter plate to the appropriate position.
3. Tighten the screw.

For 45° to 85° (see fig. 2)

1. Release the secure ring of the adapter.
2. Remove the adapter and turn negative 45° as shown.
3. Insert adapter and secure the adapter ring.
4. Loosen screw of the mechanical limiter plate.
5. Move the limiter plate to the appropriate position.
6. Tighten the screw.

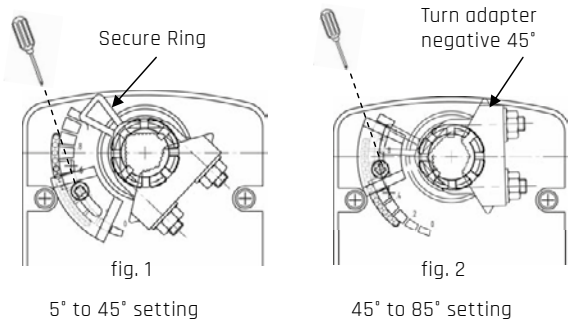

Wiring diagrams

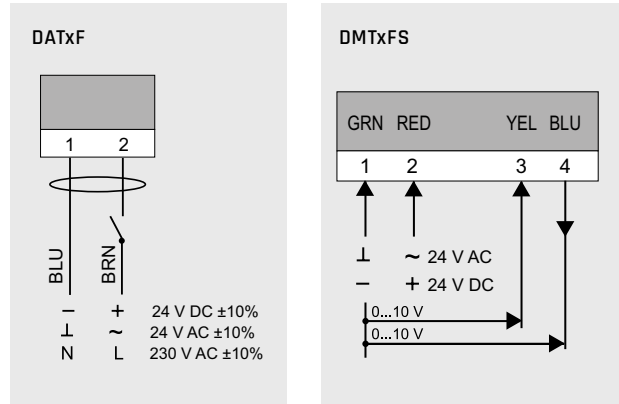

BLU - blue
BRN - brown

GRN - green
RED - red
YEL - yellow
BLU - blue

Fixed auxiliary switches

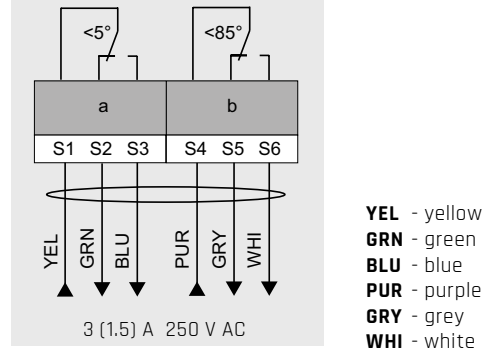

Dimension (mm)

