



Regio Maxi - Manual



THE CHALLENGER IN BUILDING AUTOMATION

DISCLAIMER

The information in this manual has been carefully checked and is believed to be correct. Regin however, makes no warranties as regards the contents of this manual and users are requested to report errors, discrepancies or ambiguities to Regin, so that corrections may be made in future editions. The information in this document is subject to change without prior notification.

The software described in this document is supplied under license by Regin and may be used or copied only in accordance with the terms of the license. No part of this document may be reproduced or transmitted in any form, in any fashion, electronically or mechanically, without the express, written permission of Regin.

COPYRIGHT

© 2015 AB Regin. All rights reserved.

TRADEMARKS

EXOdesigner, EXOreal, EXO, EXOline, EXO4 Web Server, EXOscada, Regio and Regio tool[®] are registered trademarks of AB Regin.

Windows, Windows 2000, Windows XP, Windows Vista, Windows 7, Windows 8, Windows 8.1 and Windows 10 are registered trademarks of Microsoft Corporation.

Some product names mentioned in this document are used for identification purposes only and may be the registered trademarks of their respective companies.

Contents At a Glance

- INTRODUCTION.....4**
 - CHAPTER 1 ABOUT THE MANUAL6
 - CHAPTER 2 INTRODUCTION TO REGIO MAXI7
 - CHAPTER 3 MODELS.....10
 - CHAPTER 4 TECHNICAL DATA13
- INSTALLATION 16**
 - CHAPTER 5 PREPARATIONS.....18
 - CHAPTER 6 INSTALLATION20
- APPLICATION 48**
 - CHAPTER 7 CONTROL MODES.....50
 - CHAPTER 8 SPECIAL FUNCTIONS.....56
 - CHAPTER 9 FAN CONTROL59
 - CHAPTER 10 OPERATING MODES61
 - CHAPTER 11 SETPOINT CALCULATION66
 - CHAPTER 12 ACTUATORS.....68
 - CHAPTER 13 CONTROL VIA DISPLAY69
 - CHAPTER 14 STATUS INDICATIONS.....78
 - CHAPTER 15 MAINTENANCE AND SERVICE80
- SIGNALS 82**
 - CHAPTER 16 SIGNAL TYPES84
 - CHAPTER 17 MODBUS SIGNALS.....86
 - CHAPTER 18 LONWORKS NETWORK VARIABLES101
- INDEX..... 103**

Introduction

Table of contents

Part I Introduction

CHAPTER 1 ABOUT THE MANUAL.....	6
CHAPTER 2 INTRODUCTION TO REGIO MAXI.....	7
REGIO ZONE CONTROLLERS.....	7
REGIO MAXI	8
CHAPTER 3 MODELS.....	10
RCP-UNITS.....	10
RU-UNITS	11
CHAPTER 4 TECHNICAL DATA	13
Common data	13
RCP	13
RU	15
Accessories for Regio Maxi	15

Chapter 1 About the manual

This manual covers all the models in the Regio Maxi range. This revision covers program revisions from 1.4.

Terms

Term used in the manual:

FS Factory setting

More information

More information about Regio Maxi can be found in:

- *Regio tool[®] Manual* – Describes how you configure the controllers using Regio tool[®]
- *Regio in EXO Projects* – Information on how to use Regio in the EXO system

The information is available for download from Regin's homepage, www.regincontrols.com.

Chapter 2 Introduction to Regio Maxi

Regio zone controllers

Regio is a wide series of room controllers which handle everything from heating, cooling and ventilation to lighting, humidity, CO₂ monitoring and blinds. Regio can be used for creating everything from stand-alone systems for managing the functions in one room, to large, integrated systems with a comprehensive SCADA-system.

Regio also offers TCP/IP solutions. Temperature and other functions in a room can be individually controlled from a PC connected to the office network.

Mini, Midi, Maxi

The Regio controllers are divided into three different series, Mini, Midi and Maxi.

Mini (RC) are 24 V AC stand-alone controllers for controlling heating and cooling in a room. The series consists of different room control units and a relay box for fan control. The control units are pre-programmed to handle different functions and can easily be configured. They have a built-in temperature sensor, but an external temperature sensor can also be connected.

The Midi controllers (RC-C) have the same characteristics as Mini. They can be used stand-alone or in a system with communication. The controllers are connected to bus lines such as Modbus or Regin's own bus system EXOline, to communicate with a central SCADA-system via RS485. They can also be configured for a specific application with Regin's software tool Regio tool[®].

Maxi (RCP) are 230 V AC freely programmable room controllers for handling all functions in a zone system. The controllers are pre-programmed but can be configured using Regio tool[®]. Different room units (RU-units) with built-in temperature sensor are connected to the controllers. Maxi can be connected to standardised bus systems like Modbus or EXOline, with communication via TCP/IP, RS485 or LON, and integrated with a central SCADA-system.

Applications

The Regio controllers have appealing design and functionality. They are suitable in buildings where you want optimal comfort and low energy consumption, for example offices, schools, shopping centres, airports, hotels and hospitals.

Mounting

The modular design with a separate bottom plate for wiring makes the whole Regio series easy to install and commission.

Regio Maxi

Communication The Regio Maxi controllers (RCP) can be connected to a central SCADA-system via RS485 (EXOline or Modbus), TCP/IP or LON and configured for a particular application using the configuration tool Regio tool[®], which can be downloaded free of charge from Regin's homepage www.regincontrols.com. See the manual for Regio tool[®] for more information.

LON communication Models with LON communication use LonWorks, adjusted according to the LonMark guidelines. See the LonWorks network variable list in Chapter 18, "LonWorks network variables".

LON communicates via the LON port on the RCP-unit. The configuration takes place via Regio tool[®] on a PC connected via the RS485 port on the RCP-unit. The RCP-unit should be installed in the LON network with the help of LonMaker or a corresponding computer program.

Control modes The controllers can be configured for different control modes:

- Heating
- Heating or cooling via the change-over function
- Heating/Heating
- Heating/Cooling
- Heating/Cooling with VAV-control and forced supply air function
- Heating/Cooling with VAV-control
- Cooling
- Cooling/Cooling
- Heating/Cooling/VAV
- Heating/Heating or cooling via change-over

All RCP-models can be used for controlling thermal actuators and three-point actuators. The RCP200...-models can also control 0...10 V actuators, and the RCP...F...-models can be used for fan coil control.

Application examples

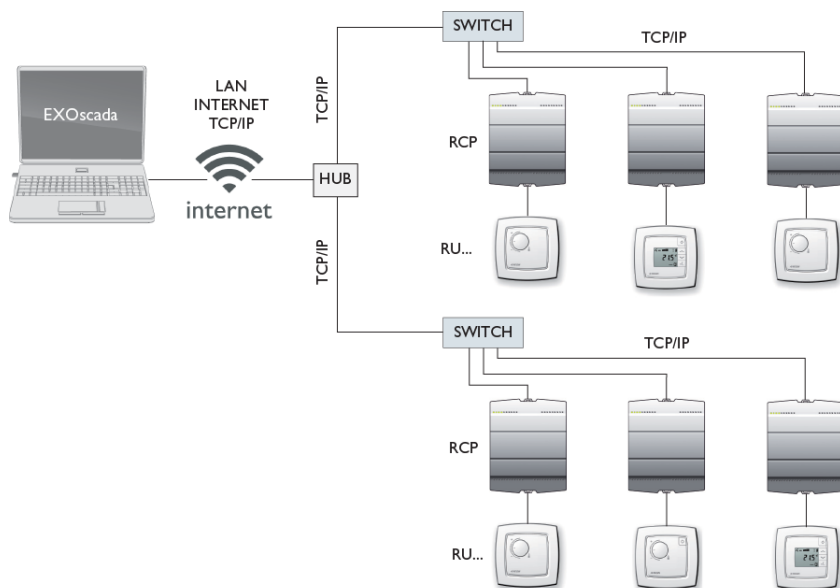
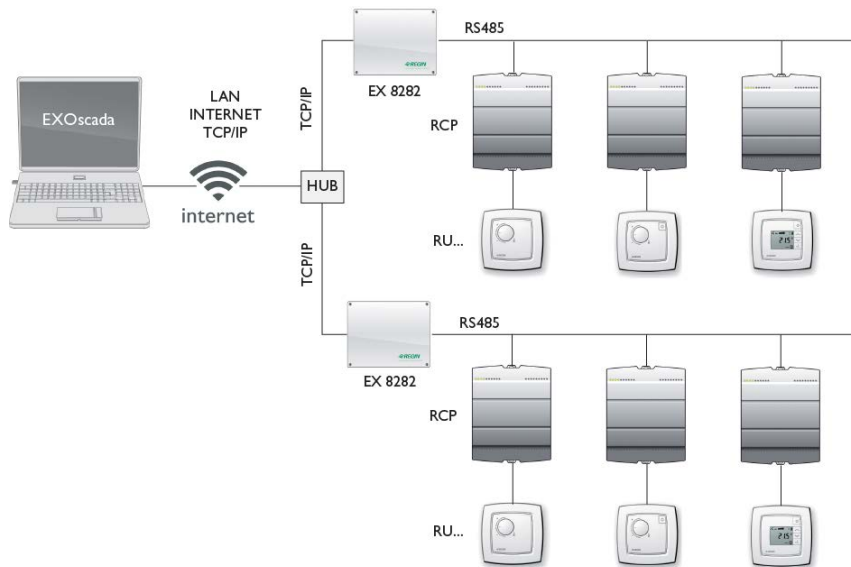
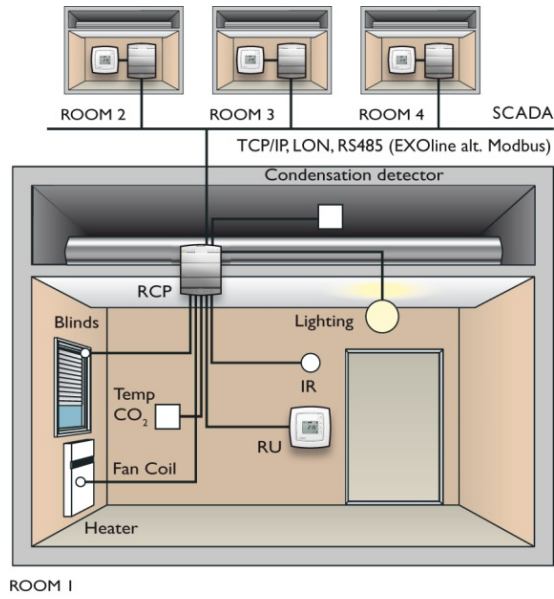

Chapter 3 Models

The Regio Maxi series consists of RCP- and RU-units, which are connected using a cable with an RJ12 connector.

RCP-units

There are 12 different RCP-controllers in the Maxi series. They can be divided according to type of control, see table 1 below.

Functions	Model name	RS485 port	TCP/IP port	LON port	Fan control	Can be combined with RU-model
Models for control of thermal actuators and/or three-point actuators	RCP100	•				RU, RU-O, RU-DO, RU-DOS
	RCP100T		•			
	RCP100L			•		
Models for control of thermal actuators and/or three-point actuators, and fan coil	RCP100F	•			•	RU-F, RU-FO, RU-DFO, RU-DOS
	RCP100FT		•		•	
	RCP100FL			•	•	
Models for control of 0...10 V-actuators and/or thermal actuators and/or three-point actuators	RCP200	•				RU, RU-O, RU-DO, RU-DOS
	RCP200T		•			
	RCP200L			•		
Models for control of 0...10 V-actuators and/or thermal actuators and/or three-point actuators, and fan coil	RCP200F	•			•	RU-F, RU-FO, RU-DFO, RU-DOS
	RCP200FT		•		•	
	RCP200FL			•	•	

Table 1. The RCP-models and their functions

Design of the RCP-models



RU-units

There are 7 different room units in the Maxi series. They can be divided according to type of control into basic models, models for fan control and a flexible model with special functions (RU-DOS). For information on how the RU-units can be combined with the RCP-controllers, see *Table 1*.

Basic models

Basic models can be used in installations with 0...10 V actuators, thermal actuators or three-point actuators.

RU-F-models

RU-models for fan control (RU-F-models) can be used for the same applications as the basic models. They also have a fan button/switch for controlling a three-speed fan (fan coil, etc.) or EC-fan.

RU-DOS

RU-DOS can be used for the same applications as the basic models and the RU-F-models. It is also possible to use the RU-DOS to control special functions like lighting control, CO₂-control, control of blinds, display of humidity and outdoor temperature via the display. Read more in Chapter 13, "Control via display".

Functions	Model name	Display	Occupancy button	CO ₂ , blinds, humidity lighting, outdoor temp	Fan control	Setpoint knob
Basic models without fan control	RU					•
	RU-O		•			•
	RU-DO	•	•			
Models for fan control (RU-F-models)	RU-F				•	•
	RU-FO		•		•	•
	RU-DFO	•	•		•	
Model with special functions	RU-DOS	•	•	•	•	

Table 2. The RU-models and their functions

Design of the RU-models

RU



RU-O



RU-DO



RU-F



RU-FO



RU-DFO



RU-DOS



Chapter 4 Technical data

The data concerns all models. For available I/O for a certain model, see the chapter *Installation*.

Common data

Ambient operation temperature	0...50°C
Ambient transport and storage temperature.....	-20...70°C
Ambient humidity	Max 95% RH
Material casing.....	Polycarbonate, PC

LVD, Low Voltage Directive

This product conforms with the requirements of European LVD standard EN 60 730-1.

EMC emission and immunity standard

This product conforms with the requirements of European EMC standards EN 61000-6-1 and EN 61000-6-3 and carries the CE mark.

RoHS

This product conforms to the Directive 2011/65/EU of the European Parliament and of the Council.

RCP

Supply voltage.....	230 V AC +/- 10%, 50/60 Hz
Fuse	Internal, automatic
Power consumption, internal electronics	2 VA
Operation	
Climatic conditions according to IEC 721-3-3.....	Class 3k3
Mechanical requirements according to IEC721-3-3	Class 3M3
Vibration	IEC60068-2-6, Test FC, vibration Sinusoidal
Shock.....	IEC60068-2-27, Test Ea
Transport	
Climatic conditions according to IEC 721-3-2.....	Class 2k3
Mechanical requirements according to IEC721-3-2	Class 2M2
Vibration	IEC60068-2-6, Test FC, vibration Sinusoidal
Shock.....	IEC60068-2-27, Test Ea
Free fall	IEC60068-2-27, Test Ed
Storage	
Climatic conditions according to IEC 721-3-1.....	Class 1k3
Built-in transformer, max capacity.....	30 VA
Max power consumption for fuse.....	30 VA
Inputs	See connection tables in the chapter <i>Wiring</i>
Terminal blocks	So-called lift type for cable cross-section 2.1 mm ²
Protection class.....	IP20
Weight.....	780 g
Casing.....	EURO-norm
Mounting	In the ceiling void
alternative	In a cabinet front with a separate mounting kit
alternative	On a TS35 DIN-rail
Operating system.....	EXOreal
Real-time clock (RTC).....	No
Dimensions.....	150 x 180 x 60 mm

Battery backup

Type.....Lithium, CR2032
Battery backup of RAM at least 5 years
Battery monitoring of RAM Yes

Communication port, Port 1

TypeRS485 (EXoline or Modbus) with automatic detection/change-over
Modbus8 bits, 1 or 2 stop bits. Odd, even (FS) or no parity
Communication speed Modbus 300, 600, 1200, 2400, 4800, 9600 or 19200 bps
Communication speed EXoline 9600 bps
Galvanic isolation from the rest of the electronics, common mode voltageMax 150 V
Data for models with TCP/IP port
Connection 10Base-T/100Base-TX auto-negotiation (RJ45)
Cable length Max 100 m (min Cat 5)
Protocol EXoline-TCP
Port 1 available on TCP/IP-modelsNo
LonWorks FT3150, gives a second communication port

Analogue inputs, AI

Temperature (PT1000)-50 +/- 150°C
accuracy (excluding sensor) +/- 0.4°C
Voltage0...10 V
input resistance 10 MOhm
accuracy (% of full scale) +/- 0.15%

Analogue outputs, AO

Output level 0...10 V DC
Max load..... 5 mA, short circuit proof

Digital inputs, DI

Type..... 24 V DC, floating contact, powered from 24 V DC output, pin 80 and 83
Logic 0..... 0...5 V DC
input current at 0 V 0 mA
input resistance 8 kOhm
Logic 1 12...24 V DC
input current at 24 V DC 3 mA

Condensation input, CI

Type.....Regin's condensation detector, KG-A/1

24 V DC-output, +C

Output level on +C 24 V DC +/- 2 V
Max total load..... 0.1 A, short circuit proof

GDO, 24 V AC-output for power supply of actuators etc.

Output level on GDO..... 24...30 V AC depending on the load
Max total load on terminals 20, 23 and 26 (connected internally) 12 VA

Digital outputs, DO4-7 (MosFet)

Type..... 24 V AC
Max continuous load is limited by available power on GDO
.....See GDO for available power for all DO:s
Max transient load for each DO..... 4.0 A, 50 ms

Digital outputs, DO1-3 (Relay)

Type.....Closing, NO
Contact data
Max switching voltage..... 250 V AC

Min switching voltage.....	12 V AC
Max continuous current DO1-3.....	4 A resistive load
Max continuous current Common, terminal 13.....	8 A resistive load
Max inrush current	20 A
Min switching current	10 mA
AC-connection	
Max switching power, resistive load.....	1000 VA
Insulation, coil-contact.....	4000 V _{RMS}

For more information about inputs and outputs, see the chapter *Wiring*.

RU

Supply voltage.....	Fed from RCP
Protection class.....	IP20
Weight.....	110 g
Max cable length between RU and RCP	30 m

Dimensions

Models without setpoint knob	95 x 95 x 28 mm
Models with setpoint knob	95 x 95 x 31 mm

Built-in temperature sensor

Type	NTC, linearised, 15 kOhm
Measuring range	0...50°C
Accuracy	+/-0.5°C at 15...30°C

RU with display

Display type	LCD with background illumination
--------------------	----------------------------------

Accessories for Regio Maxi

External temperature sensors.....	TG-R5/PT1000,TG-UH/PT1000,TG-A1/PT1000
Occupancy detector	IR24-P
Change-over	TG-A1/PT1000
Cable	Type RJ12, different lengths
CO ₂ -transmitter	CO2RT
Humidity sensor	HRT
Outdoor temperature sensor	TG-UH/PT1000
Cables for connection between RU and RCP	
Length 3 m	RU-CBL3
Length 10 m	RU-CBL10

The accessories are available from Regin. For more information, see the product sheets and instructions for each product, which can be downloaded from regincontrols.com.

Installation

Table of contents

Part II Installation

CHAPTER 5 PREPARATIONS	18
USING LABELS	18
CONFIGURATION	18
COMMISSIONING.....	19
CHAPTER 6 INSTALLATION	20
MOUNTING	20
WIRING	22
Wiring for RU-.....	23
Wiring for RCP100 / RCP100T / RCP100L	24
Wiring for RCP100F / RCP100FT / RCP100FL.....	30
Wiring for RCP200 / RCP200T / RCP200L	36
Wiring for RCP200F / RCP200FT / RCP200FL.....	42

Chapter 5 Preparations

Using labels

On the back of the units' electronics cassette, there is a set of labels which makes it easier to install large numbers of Maxi controllers. By using the labels as carriers of information for the installation engineer, much time will be saved and you can keep wiring errors at a minimum.



Figure 1. Label on the back of the RCP-controller

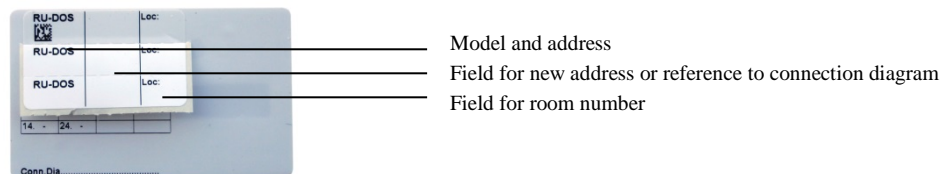

Figure 2. Label on the back of the RU-unit

The three-piece label can be split and the parts can be fastened to the installation drawing and the bottom plate of the controller. The label carries information on the communication address etc., and has a note area where you can enter a reference number to the connection diagram.

If you want to configure the RCP, it may be better to do this before sending the cassette to the installation site. For more information about configuration, see below.

The bottom plates with location and wiring information can be sent separately to the installation site for electric installation.

Configuration

The RCP-controllers are configured using Regio tool[®]. For more information, see the manual for Regio tool[®]. Some settings may also have to be made in the RU-unit. RU-models without display have dipswitches that should be set, see the section *Dipswitches* below.

The computer with Regio tool[®] is connected to the bottom plate using E-cable. E-cable is connected to terminal 41(A) & 40(B). 230 V AC is connected to L1 and N3.

Setting the dipswitches in RU (models without display)

RU-models without display have four dipswitches (SW1-4) for setting basic functions. They are found on the back of the electronics cassette.



Figure 3. Dipswitches

SW1-2

Basic setpoint (°C)	SW1	SW2
20	OFF	OFF
22 (FS)	OFF	ON
24	ON	OFF
26	ON	ON

Table 3. Setting of basic heating setpoint with dipswitch SW1 and SW2

See also the chapter “Setpoint calculation” for setting of SW1-2.

SW3

Occupied is the preset operating mode, SW3: OFF (FS). If you want the preset operating mode to be Stand-by, set SW3 in mode ON. For more information, see Chapter 10, “[Operating modes](#)”.

SW4

Not used.

RU-models with display

There are no dipswitches in RU-models with display. For these models, the corresponding settings are made in the parameter menu in the display or using Regio tool[®], see Chapter 13, “[Display handling](#)”.

Commissioning

The easiest way to set parameters is via Regio tool[®].

Calibration of a measured room temperature should be done under stable conditions.

Troubleshooting

The Manual/Auto function in Regio tool[®] makes it possible to test outputs. The output itself is not affected, only the software object that controls the output. This means that built-in safety functions will not be disregarded.

The controllers have different indications which can be used for troubleshooting, see Chapter 14, “[Status indications](#)”.

Chapter 6 Installation

Installation should only be performed by a trained professional. Since the RCP unit is powered by 230 V AC, it must be handled with great care. Always switch the power off before removing the cover and electronics cassette from the bottom plate.

Mounting

Mounting of RU

Place the controller in a location that has a temperature representative for the room. A suitable location is approx. 1.6 m above floor level in a place with unobstructed air circulation. Remove the frame by depressing the locking tab in the lower edge of the cover with a screwdriver. See figure 4.

Next, pry out the electronics cassette using the four rectangular screwdriver slots and levering against the edge of the bottom plate. See figure 5. **Note:** Take care not to damage the electronics when inserting the screwdriver into the slots.

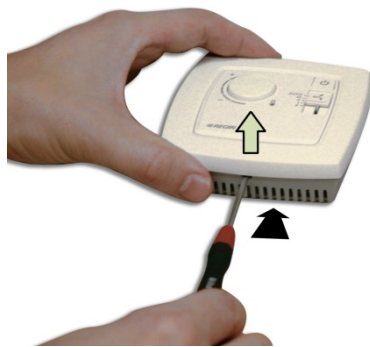

Figure 4.

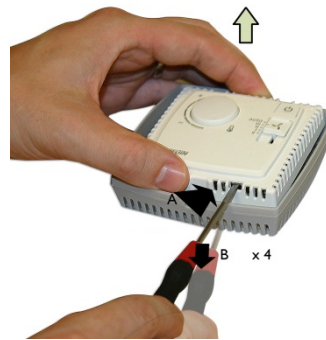

Figure 5.

The bottom plate with terminals has a number of fixing hole combinations. Select suitable holes and screw the bottom plate onto the wall or connection box, so that the arrows on the bottom plate point upwards. Do not tighten the screws too hard!

With surface-mounted cabling, break out suitable holes from the marks in the plastic.

Mounting of RCP

RCP is mounted either above a false ceiling, on a junction box plate or on a DIN-rail. The form factor of the casing is EURO norm, which makes it fit into a standard EURO norm cabinet.

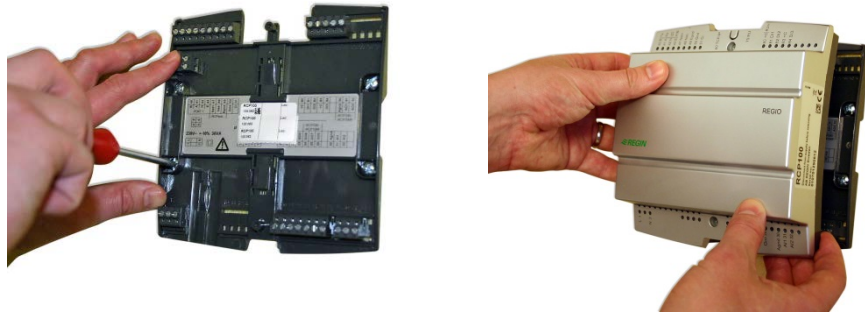

Figure 6. Mounting of RCP above a false ceiling



Figure 7. Mounting of RCP on a DIN-rail

Wiring

The figures below shows the location of the terminals. The connection diagrams and tables on the following pages show the wiring for the RU- and RCP-models.

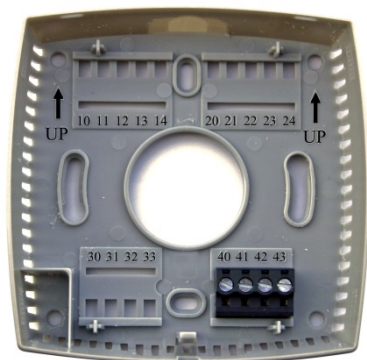

Figure 7. RU bottom plate with location of terminals

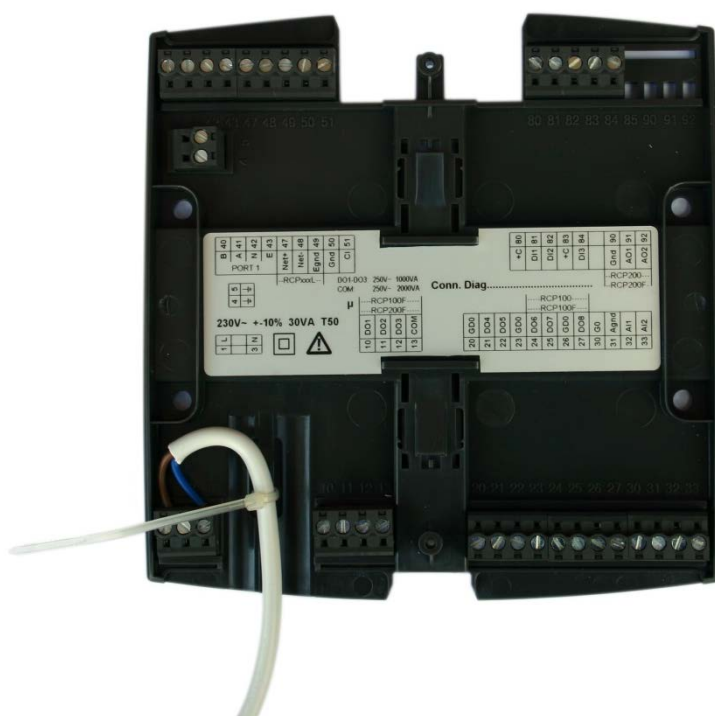
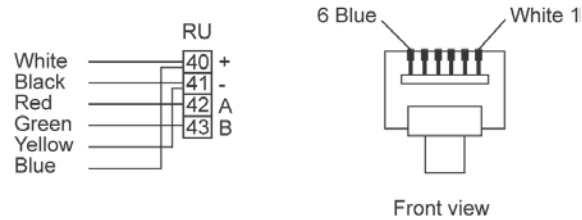

Figure 8. RCP bottom plate with location of terminals, and locking of the line voltage cable

Wiring for RU-...

RU-connection with modular cable with RJ12 fast connector (own production). The maximum cable length is 30 m.



RU-connection with Regin's cables RU-CBL3 (3 m) or RU-CBL10 (10 m) with RJ12 fast connector.

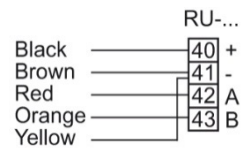

Terminal	Designation	Operation
10-33		No function
40	+5V	Power supply from RCP
41	N (0V)	Power supply from RCP
42	A	RU-Bus A
43	B	RU-Bus B

Table 4.

Wiring for RCP100 / RCP100T / RCP100L

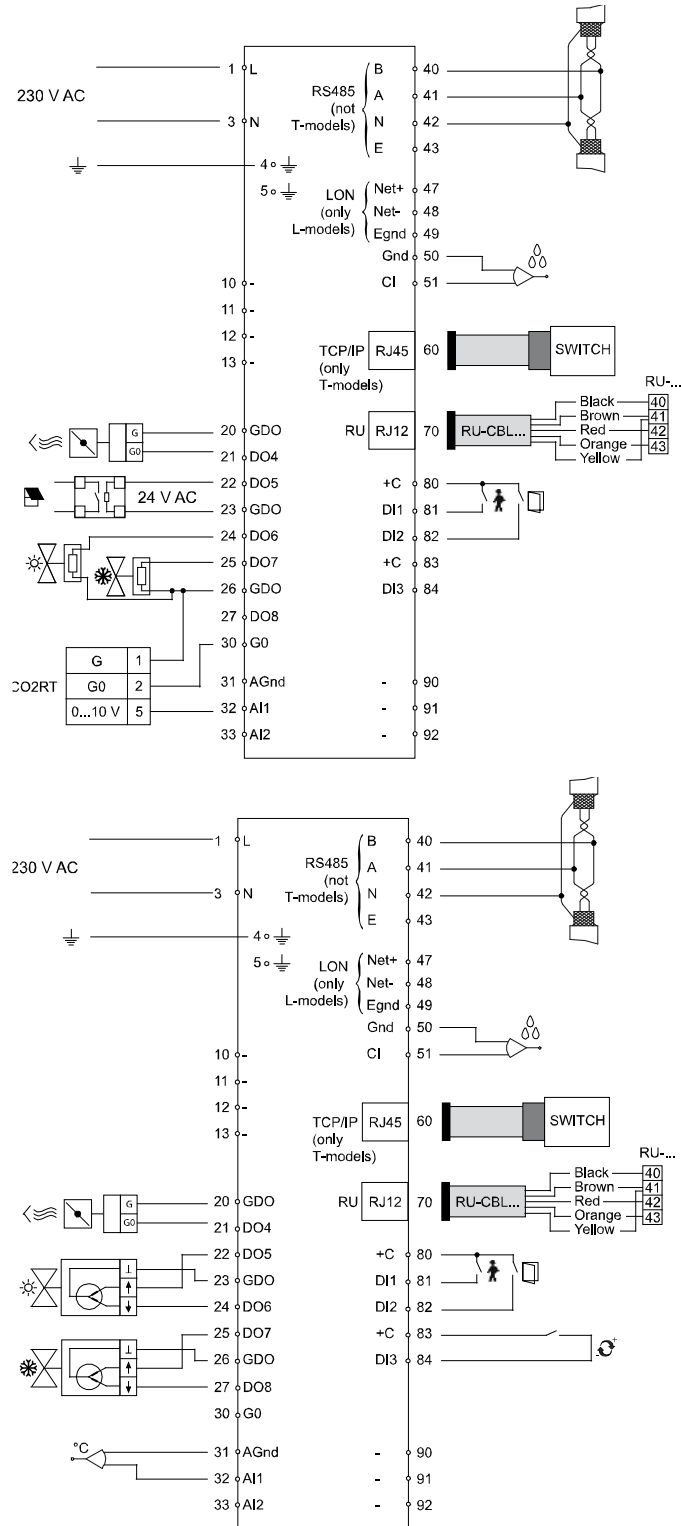

Figure 9. Connection diagrams for RCP100, RCP100T and RCP100L

Terminal	Designation	Operation	
1	L	Line	230 V AC-connection
3	N	Neutral	
4		EMI ground, yellow-green conductor	
5		EMI ground	
10-13		No function	
20	GDO	24 V AC out common for DO4-DO5.	Terminals 20, 23 and 26 are connected internally, max total load 12 VA.
21	DO4	Digital output 4, 24 V AC-output. For forced ventilation (FS). Wiring for 24 V AC-loads: 24 V AC actuator is connected between terminal 21 and terminal 20 (or terminal 23), GDO. Alternatives: - Thermal actuator, heating - Thermal actuator, cooling - Three-point actuator heating increase - Three-point actuator heating decrease - Three-point actuator cooling increase - Three-point actuator cooling decrease - Lighting control - Blind in - Blind out - Sum alarm - Sum alarm A - Sum alarm B	
22	DO5	Digital output 5, 24 V AC-output. Not configured for use (FS). Wiring for 24 V AC-loads: 24 V AC actuator is connected between terminal 22 and terminal 20, GDO. Alternatives: - Forced ventilation - Thermal actuator, heating - Thermal actuator, cooling - Three-point actuator heating increase - Three-point actuator heating decrease - Three-point actuator cooling increase - Three-point actuator cooling decrease - Lighting control - Blind in - Blind out - Sum alarm - Sum alarm A - Sum alarm B	
23	GDO	24 V AC out common for DO6-7.	Terminals 20, 23 and 26 are connected internally, max total load 12 VA.

Terminal	Designation	Operation	
24	DO6	<p>Digital output 6, 24 V AC-output. Thermal actuator, heating.</p> <p>Wiring for 24 V AC-loads: 24 V AC actuator is connected between terminal 24 and terminal 23, GDO.</p> <p>Alternatives:</p> <ul style="list-style-type: none"> - Forced ventilation - Thermal actuator, cooling - Three-point actuator heating increase - Three-point actuator heating decrease - Three-point actuator cooling increase - Three-point actuator cooling decrease - Lighting control - Blind in - Blind out - Sum alarm - Sum alarm A - Sum alarm B 	
25	DO7	<p>Digital output 7, 24 V AC-output. Thermal actuator, cooling.</p> <p>Wiring for 24 V AC-loads: 24 V AC actuator is connected between terminal 25 and terminal 23, GDO.</p> <p>Alternatives:</p> <ul style="list-style-type: none"> - Forced ventilation - Thermal actuator, heating - Three-point actuator heating increase - Three-point actuator heating decrease - Three-point actuator cooling increase - Three-point actuator cooling decrease - Lighting control - Blind in - Blind out - Sum alarm - Sum alarm A - Sum alarm B 	
26	GDO	24 V AC out for DO8.	Terminals 20, 23 and 26 are connected internally, max total load 12 VA.

Terminal	Designation	Operation
27	DO8	<p>Digital output 8, 24 V AC-output. Not configured for use (FS).</p> <p>Wiring for 24 V AC-loads: 24 V AC actuator is connected between terminal 27 and terminal 23, GDO.</p> <p>Alternatives:</p> <ul style="list-style-type: none"> - Forced ventilation - Thermal actuator, heating - Three-point actuator heating increase - Three-point actuator heating decrease - Three-point actuator cooling increase - Three-point actuator cooling decrease - Lighting control - Blind in - Blind out - Sum alarm - Sum alarm A - Sum alarm B
30	G0	<p>0 V AC.</p> <ol style="list-style-type: none"> 1. Normally used as reference ground for valve actuators and external equipment. 2. Can also be used for connecting 24 V AC external power supply to DO4 – DO8, if the available power on GDO is not enough. The power supply's 0 V is connected to terminal 30, an actuator is connected between the power supply's 24 V AC and each respective digital output.
31	AGnd	Analogue ground
32	AI1	<p>Analogue input 1. Not configured for use (FS).</p> <p>Alternatives:</p> <ul style="list-style-type: none"> - External room temperature sensor (PT1000) - Change-over sensor (PT1000) - Outdoor temperature sensor (PT1000) - Condensation detector (0...10 V) - CO₂-detector (0...10 V) - Humidity sensor (0...10 V) <p>Wiring for 0...10 V-sensor: Power supply to analogue sensors (humidity, CO₂) is connected so the sensor's 24 V AC (G0) is connected to terminal 30 (G0) and 24 V AC (G) to terminal 26 (GDO). The sensor's analogue output signal 0...10 V is connected to terminal 32.</p> <p>Wiring for PT1000-element: The sensor is connected between terminals 32 and 31, AGnd.</p>

Terminal	Designation	Operation	
33	AI2	<p>Analogue input 2.</p> <p>For switching between heating and cooling on a two-pipe system (Change-over). PT1000-sensor is connected between terminals 33 and 31, AGnd. (FS)</p> <p>Alternatives:</p> <ul style="list-style-type: none"> - External room temperature sensor (PT1000) - Outdoor temperature sensor (PT1000) - Condensation detector (0...10 V) - CO₂-transmitter (0...10 V) - Humidity sensor (0...10 V) <p>Wiring for 0...10 V-sensor:</p> <p>Power supply to analogue sensors (humidity, CO₂) is connected so the sensor's 24 V AC (G0) is connected to terminal 30 (G0) and 24 V AC (G) to terminal 26 (GDO).</p> <p>The sensor's analogue output signal 0...10 V is connected to terminal 33.</p> <p>Wiring for PT1000-element:</p> <p>The sensor is connected between terminals 33 and 31, AGnd.</p>	
40	B		EXOnline-connection, not T-models
41	A		
42	N	The 0 V reference. This should be connected to the screen of the communication cable, which in turn should be grounded at one point only.	
43	E		
47	Net+		LON-connection (only L-models)
48	Net-		
49	EGnd		
50	Gnd		
51	CI	Regin's condensation detector, KG-A/1. The sensor is connected between terminals 51 and 50, Gnd.	
60	TCP/IP		TCP/IP-connection, only T-models
70	RU	Room unit	See the section <i>Wiring for RU-...</i>
80	+C	24 V DC out common for DI1 and DI2.	
81	DI1	<p>Occupancy detector (FS), potential-free, NO. Open contact corresponds to absence.</p> <p><i>See also the section Occupancy detector in the chapter Operating modes.</i></p> <p>Wiring:</p> <p>Potential-free contact is connected between terminals 81 and 80, +C.</p> <p>Alternatives:</p> <ul style="list-style-type: none"> - Window contact, potential-free, NO. Open contact corresponds to closed window. - Condensation detector, potential-free, NO. Open contact corresponds to no condensation. - Change-over sensor, potential-free, NO. Open contact corresponds to heating demand. 	See Regio tool [®] for configuration of NO/NC. The factory setting is normally open (NO) contacts, but the contacts can be configured to NC.

Terminal	Designation	Operation	
82	DI2	<p>Window contact, potential-free, NO. Open contact corresponds to closed window (FS).</p> <p>Wiring: Potential-free contact is connected between terminals 82 and 80, +C.</p> <p>Alternatives:</p> <ul style="list-style-type: none"> - Condensation detector, potential-free, NO. Open contact corresponds to no condensation. - Occupancy detector, potential-free, NO. Open contact corresponds to absence. - Change-over sensor, potential-free, NO. Open contact corresponds to heating demand. 	<p>See Regio tool[®] for configuration of NO/NC. The factory setting is normally open (NO) contacts, but the contacts can be configured to NC.</p>
83	+C	24 V DC out common for DI3.	
84	DI3	<p>Change-over, potential-free, NO. Open contact corresponds to heating demand (FS).</p> <p>For switching between heating and cooling on a two-pipe system.</p> <p>Wiring: Potential-free contact is connected between terminals 84 and 83, +C.</p> <p>Alternatives:</p> <ul style="list-style-type: none"> - Window contact, potential-free, NO. Open contact corresponds to closed window. - Condensation detector, potential-free, NO. Open contact corresponds to no condensation. - Occupancy detector, potential-free, NO. Open contact corresponds to absence. 	<p>See Regio tool[®] for configuration of NO/NC. The factory setting is normally open (NO) contacts, but the contacts can be configured to NC.</p>
90-92		No function	

Table 5. I/O connection terminals for RCP100, RCP100T and RCP100L

Wiring for RCP100F / RCP100FT / RCP100FL

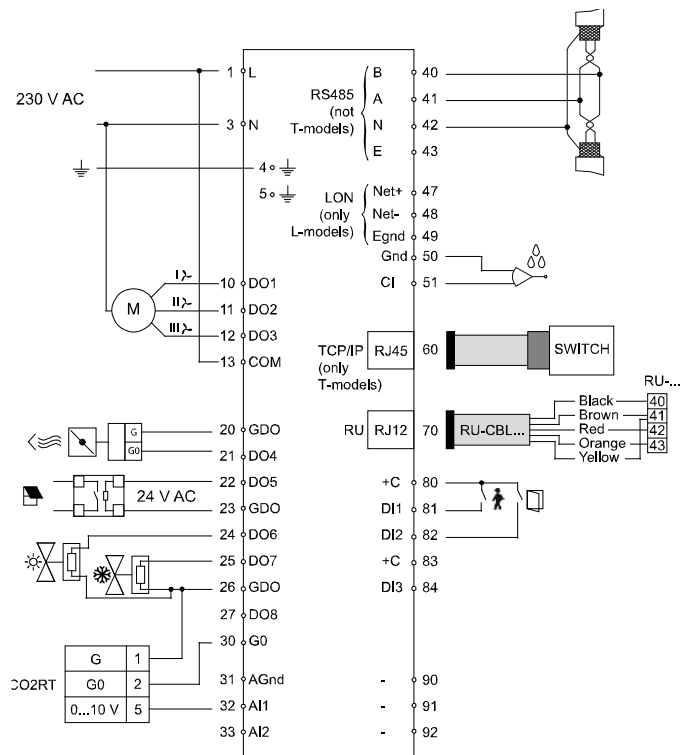

Figure 10. Connection diagram for RCP100F, RCP100FT and RCP100FL

Terminal	Designation	Operation	
1	L	Line	230 V AC-connection
3	N	Neutral	
4		EMI ground, yellow-green conductor	
5		EMI ground	
10	DO1	For fan control, low speed. 230 V AC output. Fan is connected between terminals 10 and N (Neutral).	
11	DO2	For fan control, medium speed. 230 V AC output. Fan is connected between terminals 11 and N (Neutral).	
12	DO3	For fan control, high speed. 230 V AC output. Fan is connected between terminals 12 and N (Neutral).	
13	COM	Connection of L (Line)	Common pole for DO1-3
20	GDO	24 V AC out common for DO4-DO5.	Terminals 20, 23 and 26 are connected internally, max total load 12 VA.

Terminal	Designation	Operation	
21	DO4	<p>Digital output 4, 24 V AC-output. For forced ventilation (FS).</p> <p>Wiring for 24 V AC-loads: 24 V AC actuator is connected between terminal 21 and terminal 20 (or terminal 23), GDO.</p> <p>Alternatives:</p> <ul style="list-style-type: none"> - Thermal actuator, heating - Thermal actuator, cooling - Three-point actuator heating increase - Three-point actuator heating decrease - Three-point actuator cooling increase - Three-point actuator cooling decrease - Lighting control - Blind in - Blind out - Sum alarm - Sum alarm A - Sum alarm B 	
22	DO5	<p>Digital output 5, 24 V AC-output Not configured for use (FS).</p> <p>Wiring for 24 V AC-loads: 24 V AC actuator is connected between terminal 22 and terminal 20, GDO.</p> <p>Alternatives:</p> <ul style="list-style-type: none"> - Forced ventilation - Thermal actuator, heating - Thermal actuator, cooling - Three-point actuator heating increase - Three-point actuator heating decrease - Three-point actuator cooling increase - Three-point actuator cooling decrease - Lighting control - Blind in - Blind out - Sum alarm - Sum alarm A - Sum alarm B 	
23	GDO	24 V AC out common for DO6-7.	Terminals 20, 23 and 26 are connected internally, max total load 12 VA.

Terminal	Designation	Operation	
24	DO6	<p>Digital output 6, 24 V AC-output. Thermal actuator, heating.</p> <p>Wiring for 24 V AC-loads: 24 V AC actuator is connected between terminal 24 and terminal 23, GDO.</p> <p>Alternatives:</p> <ul style="list-style-type: none"> - Forced ventilation - Thermal actuator, cooling - Three-point actuator heating increase - Three-point actuator heating decrease - Three-point actuator cooling increase - Three-point actuator cooling decrease - Lighting control - Blind in - Blind out - Sum alarm - Sum alarm A - Sum alarm B 	
25	DO7	<p>Digital output 7, 24 V AC-output. Thermal actuator, cooling.</p> <p>Wiring for 24 V AC-loads: 24 V AC actuator is connected between terminal 25 and terminal 23, GDO.</p> <p>Alternatives:</p> <ul style="list-style-type: none"> - Forced ventilation - Thermal actuator, heating - Three-point actuator heating increase - Three-point actuator heating decrease - Three-point actuator cooling increase - Three-point actuator cooling decrease - Lighting control - Blind in - Blind out - Sum alarm - Sum alarm A - Sum alarm B 	
26	GDO	24 V AC out for DO8.	Terminals 20, 23 and 26 are connected internally, max total load 12 VA.

Terminal	Designation	Operation
27	DO8	<p>Digital output 8, 24 V AC-output. Not configured for use (FS).</p> <p>Wiring for 24 V AC-loads: 24 V AC actuator is connected between terminal 27 and terminal 23, GDO.</p> <p>Alternatives:</p> <ul style="list-style-type: none"> - Forced ventilation - Thermal actuator, heating - Three-point actuator heating increase - Three-point actuator heating decrease - Three-point actuator cooling increase - Three-point actuator cooling decrease - Lighting control - Blind in - Blind out - Sum alarm - Sum alarm A - Sum alarm B
30	G0	<p>0 V AC.</p> <ol style="list-style-type: none"> 1. Normally used as reference ground for valve actuators and external equipment. 2. Can also be used for connecting 24 V AC external power supply to DO4 – DO8, if the available power on GDO is not enough. The power supply's 0 V is connected to terminal 30, an actuator is connected between the power supply's 24 V AC and each respective digital output.
31	AGnd	Analogue ground
32	AI1	<p>Analogue input 1. Not configured for use (FS).</p> <p>Alternatives:</p> <ul style="list-style-type: none"> - External room temperature sensor (PT1000) - Change-over sensor (PT1000) - Outdoor temperature sensor (PT1000) - Condensation detector (0...10 V) - CO₂-transmitter (0...10 V) - Humidity sensor (0...10 V) <p>Wiring for 0...10 V sensor: Power supply to analogue sensors (humidity, CO₂) is connected so the sensor's 24 V AC (G0) is connected to terminal 30 (G0) and 24 V AC (G) to terminal 26 (GDO). The sensor's analogue output signal 0...10 V is connected to terminal 32.</p> <p>Wiring for PT1000-element: The sensor is connected between terminals 32 and 31, AGnd.</p>

Terminal	Designation	Operation	
33	AI2	<p>Analogue input 2.</p> <p>For switching between heating and cooling on a two-pipe system (Change-over). PT1000-sensor is connected between terminals 33 and 31, AGnd. (FS)</p> <p>Alternatives:</p> <ul style="list-style-type: none"> - External room temperature sensor (PT1000) - Outdoor temperature sensor (PT1000) - Condensation detector (0...10 V) - CO₂-transmitter (0...10 V) - Humidity sensor (0...10 V) <p>Wiring for 0...10 V sensor:</p> <p>Power supply to analogue sensors (humidity, CO₂) is connected so the sensor's 24 V AC (G0) is connected to terminal 30 (G0) and 24 V AC (G) to terminal 26 (GDO).</p> <p>The sensor's analogue output signal 0...10 V is connected to terminal 33.</p> <p>Wiring for PT1000-element</p> <p>The sensor is connected between terminals 33 and 31, AGnd.</p>	
40	B		EXOline-connection, not T-models
41	A		
42	N	The 0 V reference. This should be connected to the screen of the communication cable, which in turn should be grounded at one point only.	
43	E		
47	Net+		LON-connection (only L-models)
48	Net-		
49	EGnd		
50	Gnd		
51	CI	Regin's condensation detector, KG-A/1. The sensor is connected between terminals 51 and 50, Gnd.	
60	TCP/IP		TCP/IP-connection, only T-models
70	RU	Room unit	See the section <i>Wiring for RU-...</i>
80	+C	24 V DC out common for DI1 and DI2.	
81	DI1	<p>Occupancy detector (FS), potential-free, NO. Open contact corresponds to absence.</p> <p><i>See also the section Occupancy detector in the chapter Operating modes.</i></p> <p>Wiring:</p> <p>Potential-free contact is connected between terminals 81 and 80, +C.</p> <p>Alternatives:</p> <ul style="list-style-type: none"> - Window contact, potential-free, NO. Open contact corresponds to closed window. - Condensation detector, potential-free, NO. Open contact corresponds to no condensation. - Change-over sensor, potential-free, NO. Open contact corresponds to heating demand. 	See Regio tool [®] for configuration of NO/NC. The factory setting is normally open (NO) contacts, but the contacts can be configured to NC.

Terminal	Designation	Operation	
82	DI2	Window contact, potential-free, NO. Open contact corresponds to closed window (FS). Wiring: Potential-free contact is connected between terminals 82 and 80, +C. Alternatives: - Condensation detector, potential-free, NO. Open contact corresponds to no condensation. - Occupancy detector, potential-free, NO. Open contact corresponds to absence. - Change-over sensor, potential-free, NO. Open contact corresponds to heating demand.	See Regio tool [®] for configuration of NO/NC. The factory setting is normally open (NO) contacts, but the contacts can be configured to NC.
83	+C	24 V DC out common for DI3.	
84	DI3	Change-over, potential-free, NO. Open contact corresponds to heating demand (FS). For switching between heating and cooling on a two-pipe system. Wiring: Potential-free contact is connected between terminals 84 and 83, +C. Alternatives: - Window contact, potential-free, NO. Open contact corresponds to closed window. - Condensation detector, potential-free, NO. Open contact corresponds to no condensation. - Occupancy detector, potential-free, NO. Open contact corresponds to absence.	See Regio tool [®] for configuration of NO/NC. The factory setting is normally open (NO) contacts, but the contacts can be configured to NC.
90-92		No function	

Table 6. I/O connection terminals for RCP100F, RCP100FT and RCP100FL

Wiring for RCP200 / RCP200T / RCP200L

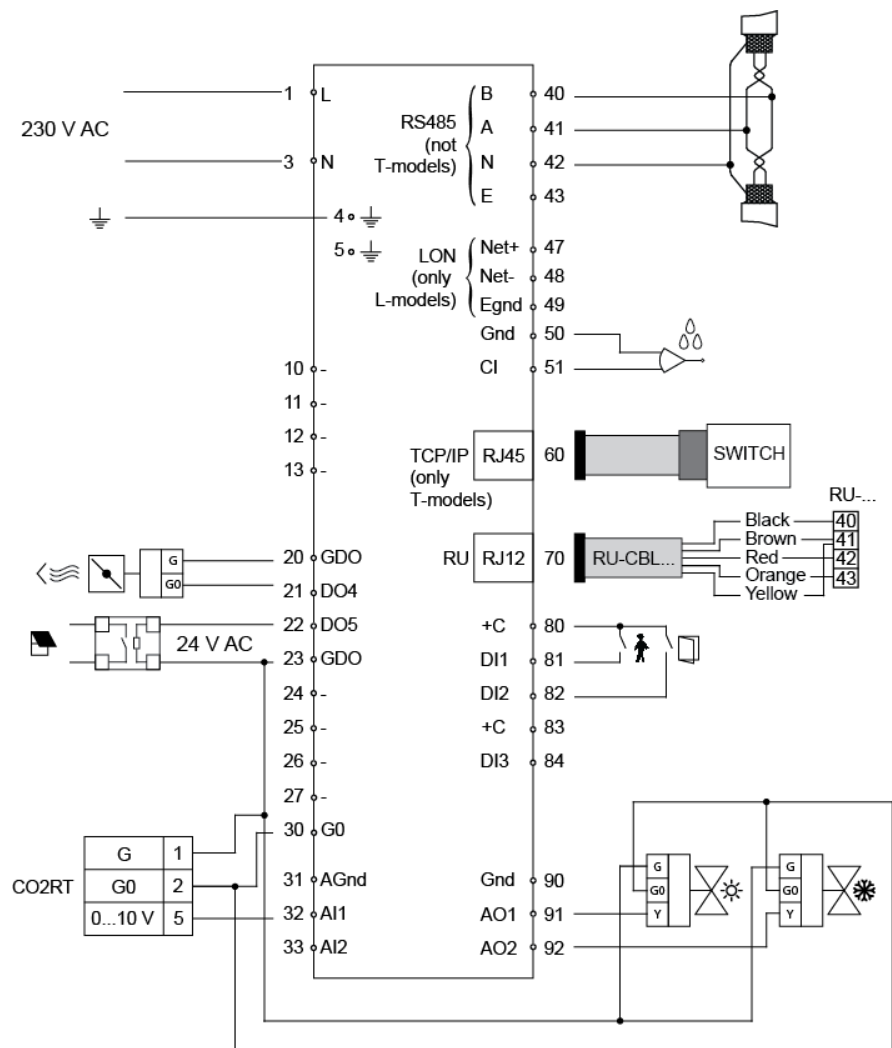

Figure 11. Connection diagrams for RCP200, RCP200T and RCP200L

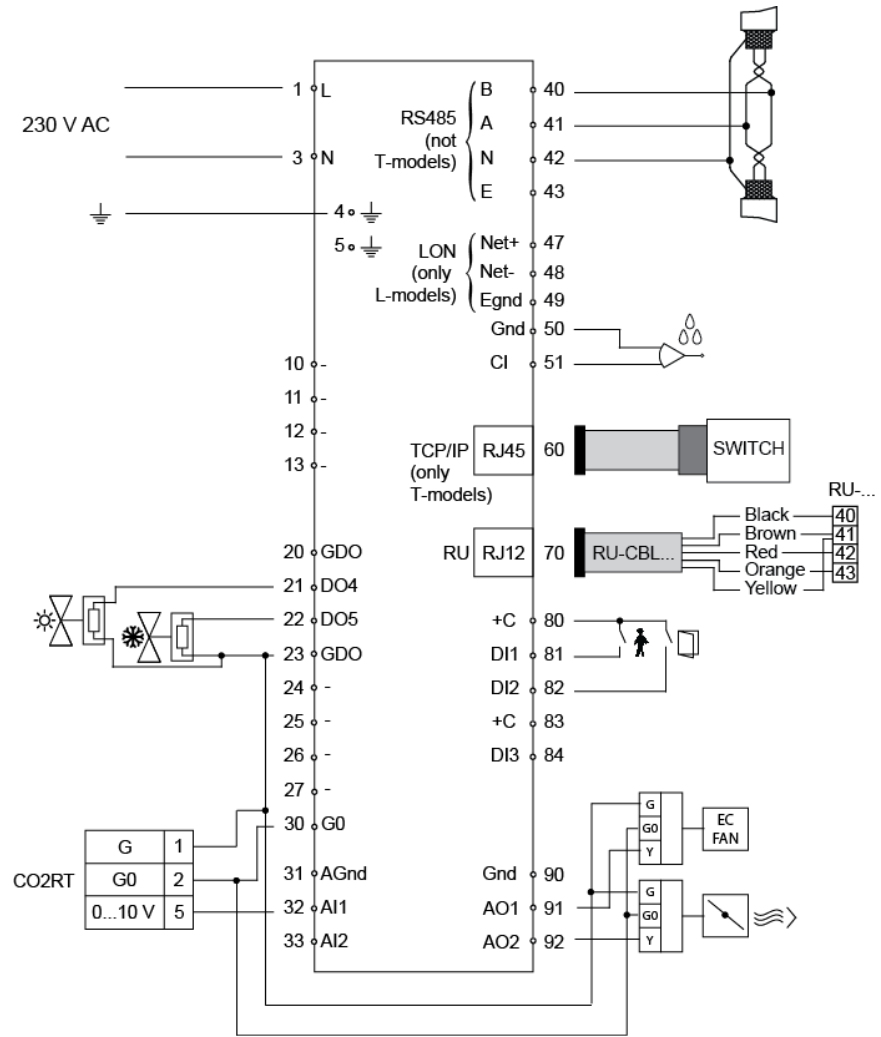

Figure 12. Connection diagram for RCP200 with EC fan control

Terminal	Designation	Operation	
1	L	Line	230 V AC-connection
3	N	Neutral	
4		EMI ground, yellow-green conductor	
5		EMI ground	
10-13		No function	
20	GDO	24 V AC out common for DO.	Terminals 20 and 23 are connected internally, max total load 12 VA.

Terminal	Designation	Operation	
21	DO4	Digital output 4, 24 V AC-output. For forced ventilation (FS). Wiring for 24 V AC-loads: 24 V AC actuator is connected between terminal 21 and terminal 20 (or terminal 23), GDO. Alternatives: - Thermal actuator, heating - Thermal actuator, cooling - Three-point actuator heating increase - Three-point actuator heating decrease - Three-point actuator cooling increase - Three-point actuator cooling decrease - Lighting control - Blind in - Blind out - Sum alarm - Sum alarm A - Sum alarm B	
22	DO5	Digital output 5, 24 V AC-output. Not configured for use (FS). Wiring for 24 V AC-loads: 24 V AC actuator is connected between terminal 22 and terminal 20 (or terminal 23), GDO. Alternatives: - Forced ventilation - Thermal actuator, heating - Thermal actuator, cooling - Three-point actuator heating increase - Three-point actuator heating decrease - Three-point actuator cooling increase - Three-point actuator cooling decrease - Lighting control - Blind in - Blind out - Sum alarm - Sum alarm A - Sum alarm B	
23	GDO	24 V AC out common for DO.	Terminals 20 and 23 are connected internally, max total load 12 VA.
24-27		No function	
30	G0	0 V AC. 1. Normally used as reference ground for valve actuators and external equipment. 2. Can also be used for connecting 24 V AC external power supply to DO4 – DO8, if the available power on GDO is not enough. The power supply's 0 V is connected to terminal 30, an actuator is connected between the power supply's 24 V AC and each respective digital output.	
31	AGnd	Analogue ground	

Terminal	Designation	Operation	
32	AI1	<p>Analogue input 1. Not configured for use (FS).</p> <p>Alternatives:</p> <ul style="list-style-type: none"> - External room temperature sensor (PT1000) - Change-over sensor (PT1000) - Outdoor temperature sensor (PT1000) - Condensation detector (0...10 V) - CO₂-transmitter (0...10 V) - Humidity sensor (0...10 V) <p>Wiring for 0...10 V-sensor: Power supply to analogue sensors (humidity, CO₂) is connected so the sensor's 24 V AC (G0) is connected to terminal 30 (G0) and 24 V AC (G) to terminal 26 (GDO). The sensor's analogue output signal 0...10 V is connected to terminal 32.</p> <p>Wiring for PT1000-element: The sensor is connected between terminals 32 and 31, AGnd.</p>	
33	AI2	<p>Analogue input 2. For switching between heating and cooling on a two-pipe system (Change-over). PT1000-sensor is connected between terminals 33 and 31, AGnd. (FS)</p> <p>Alternatives:</p> <ul style="list-style-type: none"> - External room temperature sensor (PT1000) - Outdoor temperature sensor (PT1000) - Condensation detector (0...10 V) - CO₂-transmitter (0...10 V) - Humidity sensor (0...10 V) <p>Wiring for 0...10 V-sensor: Power supply to analogue sensors (humidity, CO₂) is connected so the sensor's 24 V AC (G0) is connected to terminal 30 (G0) and 24 V AC (G) to terminal 26 (GDO). The sensor's analogue output signal 0...10 V is connected to terminal 33.</p> <p>Wiring for PT1000-element: The sensor is connected between terminals 33 and 31, AGnd.</p>	
40	B		EXoline-connection, not T-models
41	A		
42	N	The 0 V reference. This should be connected to the screen of the communication cable, which in turn should be grounded at one point only.	
43	E		
47	Net+		LON-connection (only L-models)
48	Net-		
49	EGnd		
50	Gnd		
51	CI	Regin's condensation detector, KG-A/1. The sensor is connected between terminals 51 and 50, Gnd.	
60	TCP/IP		TCP-connection, only T-models
70	RU	Room sensor	See the section <i>Wiring for RU...</i>
80	+C	24 V DC out common for DI1 and DI2	

Terminal	Designation	Operation	
81	DI1	<p>Digital input 1, 24 V DC. Occupancy detector (FS), potential-free, NO. Open contact corresponds to absence. <i>See also the section Occupancy detector in the chapter Operating modes.</i></p> <p>Wiring: Potential-free contact is connected between terminals 81 and 80, +C.</p> <p>Alternatives:</p> <ul style="list-style-type: none"> - Window contact, potential-free, NO. Open contact corresponds to closed window. - Condensation detector, potential-free, NO. Open contact corresponds to no condensation. - Change-over sensor, potential-free, NO. Open contact corresponds to heating demand. 	<p>See Regio tool[®] for configuration of NO/NC. The factory setting is normally open (NO) contacts, but the contacts can be configured to NC.</p>
82	DI2	<p>Digital input 2, 24 V DC. Window contact, potential-free, NO. Open contact corresponds to closed window. (FS)</p> <p>Wiring: Potential-free contact is connected between terminals 82 and 80, +C.</p> <p>Alternatives:</p> <ul style="list-style-type: none"> - Condensation detector, potential-free, NO. Open contact corresponds to no condensation. - Occupancy detector, potential-free, NO. Open contact corresponds to absence. - Change-over sensor, potential-free, NO. Open contact corresponds to heating demand. 	<p>See Regio tool[®] for configuration of NO/NC. The factory setting is normally open (NO) contacts, but the contacts can be configured to NC.</p>
83	+C	24 V DC out common for DI3	
84	DI3	<p>Digital input 3, 24 V DC. Not configured for use (FS).</p> <p>Wiring: Potential-free contact is connected between terminals 84 and 83, +C.</p> <p>Alternatives:</p> <ul style="list-style-type: none"> - Window contact, potential-free, NO. Open contact corresponds to closed window. - Condensation detector, potential-free, NO. Open contact corresponds to no condensation. - Occupancy detector, potential-free, NO. Open contact corresponds to absence. - Change-over, potential-free, NO. Open contact corresponds to heating demand. For switching between heating and cooling on a two-pipe system. 	<p>See Regio tool[®] for configuration of NO/NC. The factory setting is normally open (NO) contacts, but the contacts can be configured to NC.</p>
90	Gnd	Reference ground for AO1-AO2 when high-ohm loads are used and maximal accuracy is desired.	
91	AO1	<p>Analogue output 1. Valve actuator, 0...10 V DC, max 5 mA. Control state: heating (FS).Wiring: Valve actuator is connected between terminals 91 and 30, G0.</p> <p>Alternative:</p> <ul style="list-style-type: none"> - Valve actuator, 0...10 V DC, max 5 mA. Control state: cooling. - Output for 0...10 V DC damper control - Output for 0...10 V DC EC fan 	

Terminal	Designation	Operation
92	AO2	<p>Analogue output 2. Valve actuator, 0...10 V DC, max 5 mA. Control state: cooling.</p> <p>Wiring: Valve actuator is connected between terminals 92 and 30, G0.</p> <p>Alternative:</p> <ul style="list-style-type: none"> - Valve actuator, 0...10 V DC, max 5 mA. Control state: heating. - Output for 0...10 V DC damper control - Output for 0...10 V DC EC fan

Table 7. I/O connection terminals for RCP200, RCP200T and RCP200L

Wiring for RCP200F / RCP200FT / RCP200FL

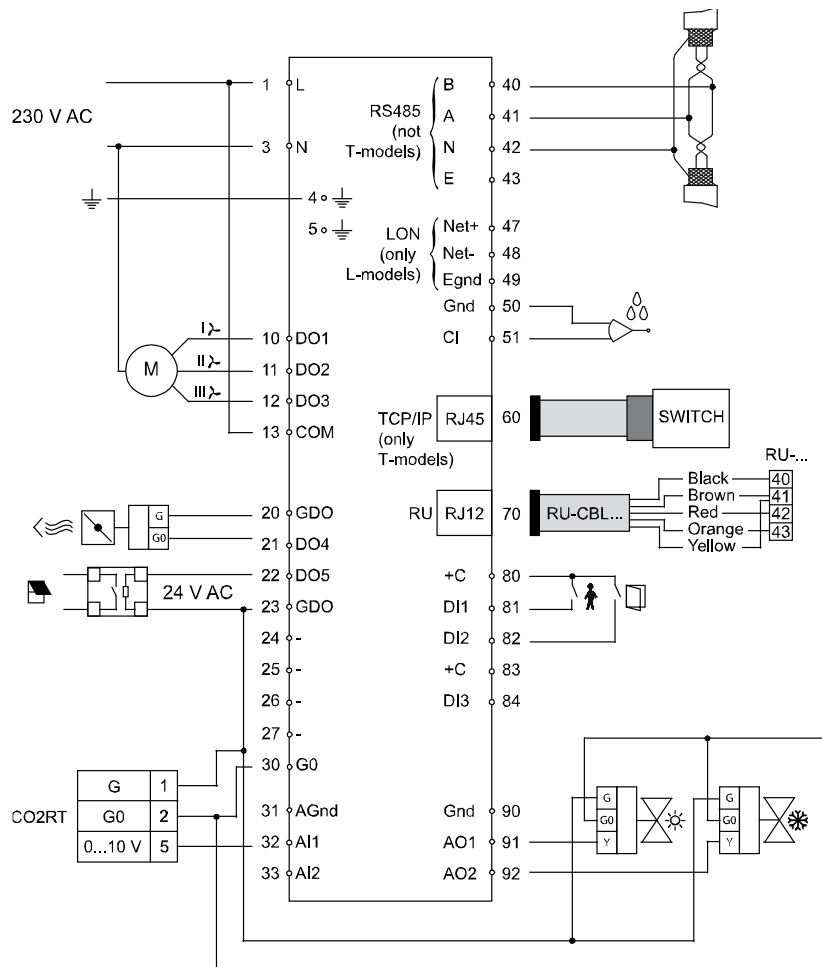

Figure 13. Connection diagram for RCP200F, RCP200FT and RCP200FL

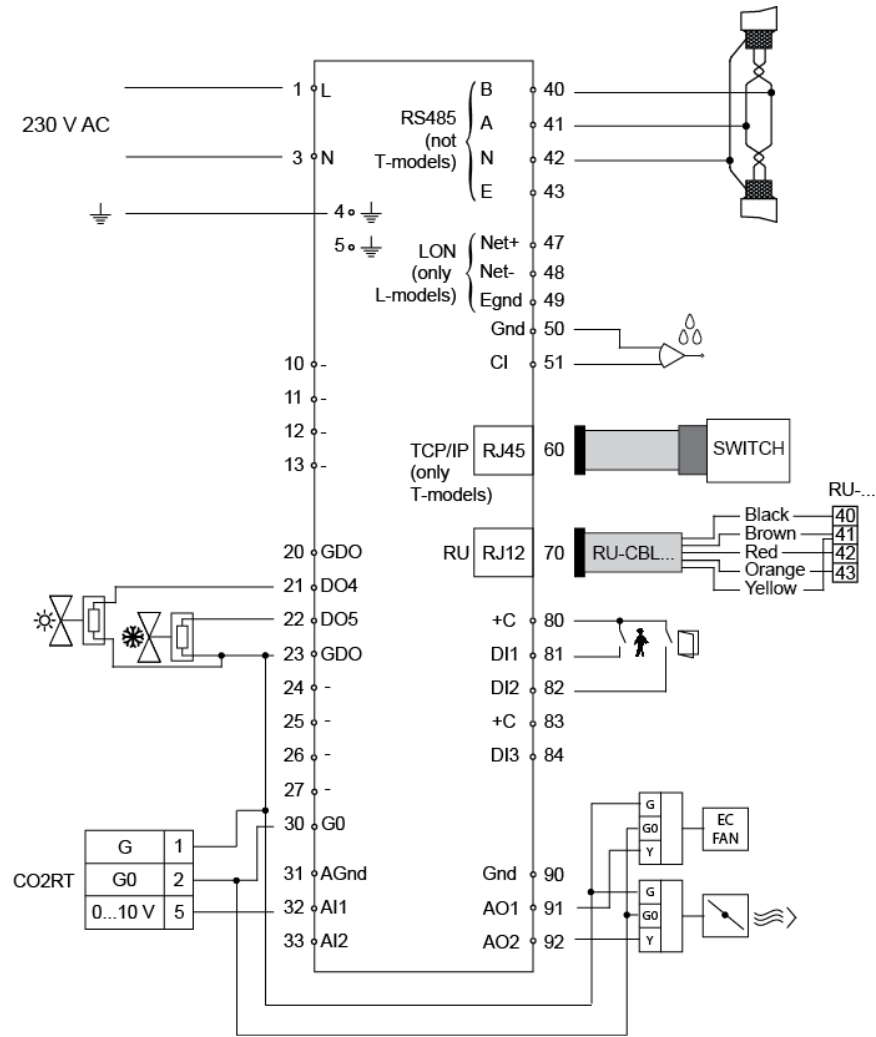

Figure 14. Connection diagram for RCP200 with fan control

Terminal	Designation	Operation	
1	L	Line	230 V AC-connection
3	N	Neutral	
4		EMI ground, yellow-green conductor	
5		EMI ground	
10	DO1	For fan control, low speed. 230 V AC output. Fan is connected between terminals 10 and N (Neutral).	
11	DO2	For fan control, medium speed. 230 V AC output. Fan is connected between terminals 11 and N (Neutral).	
12	DO3	For fan control, high speed. 230 V AC output. Fan is connected between terminals 12 and N (Neutral).	
13	COM	Connection of L (Line)	Common pole for DO1-3
20	GDO	24 V AC out common for DO.	Terminals 20 and 23 are connected internally, max total load 12 VA.

Terminal	Designation	Operation	
21	DO4	<p>Digital output 4, 24 V AC-output. For forced ventilation (FS).</p> <p>Wiring for 24 V AC-loads: 24 V AC actuator is connected between terminal 21 and terminal 20 (or terminal 23), GDO.</p> <p>Alternatives:</p> <ul style="list-style-type: none"> - Thermal actuator, heating - Thermal actuator, cooling - Three-point actuator heating increase - Three-point actuator heating decrease - Three-point actuator cooling increase - Three-point actuator cooling decrease - Lighting control - Blind in - Blind out - Sum alarm - Sum alarm A - Sum alarm B 	
22	DO5	<p>Digital output 5, 24 V AC-output. Not configured for use (FS).</p> <p>Wiring for 24 V AC-loads: 24 V AC actuator is connected between terminal 22 and terminal 20 (or terminal 23), GDO.</p> <p>Alternatives:</p> <ul style="list-style-type: none"> - Forced ventilation - Thermal actuator, heating - Thermal actuator, cooling - Three-point actuator heating increase - Three-point actuator heating decrease - Three-point actuator cooling increase - Three-point actuator cooling decrease - Lighting control - Blind in - Blind out - Sum alarm - Sum alarm A - Sum alarm B 	
23	GDO	24 V AC out common for DO.	Terminals 20 and 23 are connected internally, max total load 12 VA.
24-27		No function	
30	G0	<p>0 V AC.</p> <ol style="list-style-type: none"> 1. Normally used as reference ground for valve actuators and external equipment. 2. Can also be used for connecting 24 V AC external power supply to DO4 – DO8, if the available power on GDO is not enough. The power supply's 0 V is connected to terminal 30, an actuator is connected between the power supply's 24 V AC and each respective digital output. 	
31	AGnd	Analogue ground	

Terminal	Designation	Operation	
32	AI1	<p>Analogue input 1. Not configured for use (FS).</p> <p>Alternatives:</p> <ul style="list-style-type: none"> - External room temperature sensor (PT1000) - Change-over sensor (PT1000) - Outdoor temperature sensor (PT1000) - Condensation detector (0...10 V) - CO₂-transmitter (0...10 V) - Humidity sensor (0...10 V) <p>Wiring for 0...10 V-sensor: Power supply to analogue sensors (humidity, CO₂) is connected so the sensor's 24 V AC (G0) is connected to terminal 30 (G0) and 24 V AC (G) to terminal 26 (GDO). The sensor's analogue output signal 0...10 V is connected to terminal 32.</p> <p>Wiring for PT1000-element The sensor is connected between terminals 32 and 31, AGnd.</p>	
33	AI2	<p>Analogue input 2. For switching between heating and cooling on a two-pipe system (Change-over). PT1000-sensor is connected between terminals 33 and 31, AGnd. (FS)</p> <p>Alternatives:</p> <ul style="list-style-type: none"> - External room temperature sensor (PT1000) - Outdoor temperature sensor (PT1000) - Condensation detector (0...10 V) - CO₂-transmitter (0...10 V) - Humidity sensor (0...10 V) <p>Wiring for 0...10 V-sensor: Power supply to analogue sensors (humidity, CO₂) is connected so the sensor's 24 V AC (G0) is connected to terminal 30 (G0) and 24 V AC (G) to terminal 26 (GDO). The sensor's analogue output signal 0...10 V is connected to terminal 33.</p> <p>Wiring for PT1000-element The sensor is connected between terminals 33 and 31, AGnd</p>	
40	B		EXoline-connection, not T-models
41	A		
42	N	The 0 V reference. This should be connected to the screen of the communication cable, which in turn should be grounded at one point only.	
43	E		
47	Net+		LON-connection (only L-models)
48	Net-		
49	EGnd		
50	Gnd		
51	CI	Regin's condensation detector, KG-A/1. The sensor is connected between terminals 51 and 50, Gnd.	
60	TCP/IP		TCP-connection, only T-models
70	RU	Room sensor	See the section <i>Wiring for RU...</i>
80	+C	24 V DC out common for DI1 and DI2	

Terminal	Designation	Operation	
81	DI1	<p>Digital input 1, 24 V DC. Occupancy detector (FS), potential-free, NO. Open contact corresponds to absence. <i>See also the section Occupancy detector in the chapter Operating modes.</i></p> <p>Wiring: Potential-free contact is connected between terminals 81 and 80, +C.</p> <p>Alternatives:</p> <ul style="list-style-type: none"> - Window contact, potential-free, NO. Open contact corresponds to closed window. - Condensation detector, potential-free, NO. Open contact corresponds to no condensation. - Change-over sensor, potential-free, NO. Open contact corresponds to heating demand. 	<p>See Regio tool[®] for configuration of NO/NC. The factory setting is normally open (NO) contacts, but the contacts can be configured to NC.</p>
82	DI2	<p>Digital input 2, 24 V DC. Window contact, potential-free, NO. Open contact corresponds to closed window (FS).</p> <p>Wiring: Potential-free contact is connected between terminals 82 and 80, +C.</p> <p>Alternatives:</p> <ul style="list-style-type: none"> - Condensation detector, potential-free, NO. Open contact corresponds to no condensation. - Occupancy detector, potential-free, NO. Open contact corresponds to absence. - Change-over sensor, potential-free, NO. Open contact corresponds to heating demand. 	<p>See Regio tool[®] for configuration of NO/NC. The factory setting is normally open (NO) contacts, but the contacts can be configured to NC.</p>
83	+C	24 V DC out common for DI3	
84	DI3	<p>Digital input 3, 24 V DC. Not configured for use (FS).</p> <p>Wiring: Potential-free contact is connected between terminals 84 and 83, +C.</p> <p>Alternatives:</p> <ul style="list-style-type: none"> - Window contact, potential-free, NO. Open contact corresponds to closed window. - Condensation detector, potential-free, NO. Open contact corresponds to no condensation. - Occupancy detector, potential-free, NO. Open contact corresponds to absence. - Change-over, potential-free, NO. Open contact corresponds to heating demand. For switching between heating and cooling on a two-pipe system. 	<p>See Regio tool[®] for configuration of NO/NC. The factory setting is normally open (NO) contacts, but the contacts can be configured to NC.</p>
90	Gnd	Reference ground for AO1-AO2 when high-ohm loads are used and maximal accuracy is desired.	
91	AO1	<p>Analogue output 1. Valve actuator, 0...10 V DC, max 5 mA. Control state: heating (FS).</p> <p>Wiring: Valve actuator is connected between terminals 91 and 30, G0.</p> <p>Alternative:</p> <ul style="list-style-type: none"> - Valve actuator, 0...10 V DC, max 5 mA. Control state: cooling. - Output for 0...10 V DC damper control - Output for 0...10 V DC EC-fan 	

Terminal	Designation	Operation
92	AO2	<p>Analogue output 2. Valve actuator, 0...10 V DC, max 5 mA. Control state: cooling.</p> <p>Wiring: Valve actuator is connected between terminals 92 and 30, G0.</p> <p>Alternative:</p> <ul style="list-style-type: none"> - Valve actuator, 0...10 V DC, max 5 mA. Control state: heating. - Output for 0...10 V DC damper control - Output for 0...10 V DC EC-fan

Table 8. I/O connection terminals for RCP200F, RCP200FT and RCP200FL

Application

Table of contents

Part III Application

CHAPTER 7 CONTROL MODES	50
THE CONTROL MODES	50
ADDITIONAL FEATURES.....	54
CHAPTER 8 SPECIAL FUNCTIONS	56
CHANGE-OVER FUNCTION	56
FORCED VENTILATION	56
CONDENSATION DETECTOR.....	56
CO ₂ CONTROL.....	57
FROST PROTECTION	57
ELECTRICAL HEATER.....	57
ACTUATOR EXERCISE	58
LIGHTING CONTROL.....	58
BLINDS CONTROL	58
HUMIDITY SENSOR.....	58
OUTDOOR TEMPERATURE SENSOR	58
CHAPTER 9 FAN CONTROL.....	59
FAN SPEED CONTROL.....	59
EC FAN CONTROL	60
CHAPTER 10 OPERATING MODES.....	61
DIFFERENT OPERATING MODES	61
ACTIVATION OF THE DIFFERENT OPERATING MODES	62
CHAPTER 11 SETPOINT CALCULATION	66
CHAPTER 12 ACTUATORS	68
CHAPTER 13 CONTROL VIA DISPLAY	69
DISPLAY HANDLING.....	69
RU-DOS FEATURES	70
THE PARAMETER MENU	70
CHAPTER 14 STATUS INDICATIONS	78

Chapter 7 Control modes

The control modes

The controllers can be configured for different control modes:

- Heating
- Heating/Heating
- Heating or cooling via the change-over function
- Heating/Cooling
- Heating/Cooling with VAV-control and forced supply air function
- Heating/Cooling with VAV-control
- Cooling
- Cooling/Cooling
- Heating/Cooling/VAV (only RCP200xx)
- Heating/Heating or cooling via change-over (only RCP100Fx, RCP200xx)

Heating

In control mode Heating, the unit is always a heating controller and controls according to the heating setpoint plus/minus the setpoint offset. The setpoint can be adjusted in the display or via the setpoint knob, as well as via a central system.

Heating/Heating

In control mode Heating/Heating, the unit is always a heating controller and controls according to the basic heating setpoint plus the setpoint offset. When the controller output signal reaches 50%, it is divided between two actuators. 0...48% of the signal is sent to actuator 1 and 52...100% of the signal is sent to actuator 2. See the figure below.

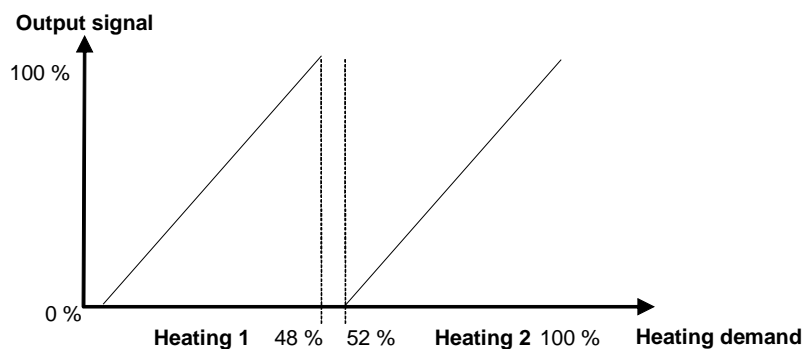

Heating or cooling via change-over

This control mode is similar to the Heating control mode but has a change-over function. I.e., when the change-over input is active the controller will become a cooling controller and control according to the basic cooling setpoint plus/minus the setpoint offset.

This control mode is used for installations with 2-pipe systems. It makes it possible to use the same pipe for both heating and cooling, depending on whether heating or cooling is required.

See more in the section “Change-over”.

Heating/Cooling

In control state Heating/Cooling, the controller functions as a heating controller when the room temperature is lower than the basic heating setpoint plus half the neutral zone. The neutral zone is the difference in temperature between the heating setpoint and the cooling setpoint. When the room temperature exceeds this limit, the controller becomes a cooling controller. There is a hysteresis of 0.1°C when the controller changes from heating to cooling controller and vice versa. When the controller is heating, it controls according to the basic heating setpoint plus the setpoint offset, and when it is cooling according to the basic cooling setpoint plus the setpoint adjustment.

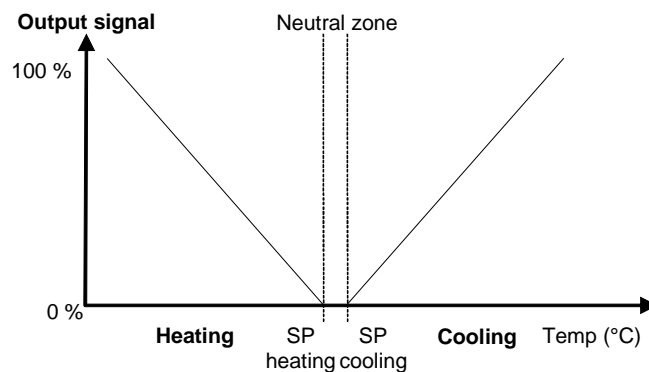

Heating/Cooling with VAV-control and forced supply air function

Like control state Heating/Cooling but the cooling is controlled via a supply air damper (sub-tempered supply air). When the ventilation is forced (see the section “Forced ventilation”), the cooling output is set to full cooling (full supply air volume), regardless of what the controller output signal is.

Heating/Cooling with VAV-control

Heating and cooling are controlled in the same way as in the VAV-control above. The damper cannot be forced like above. There is also a function that opens the supply air damper on heating demand. This is normally always required if the heater is placed in the supply air duct, to carry the heat to the room. A maximum limit is set for the opening of the damper on heating demand. The factory setting is zero, which means that the function to open the damper on heating demand is not active. The basic flow can also be set separately.

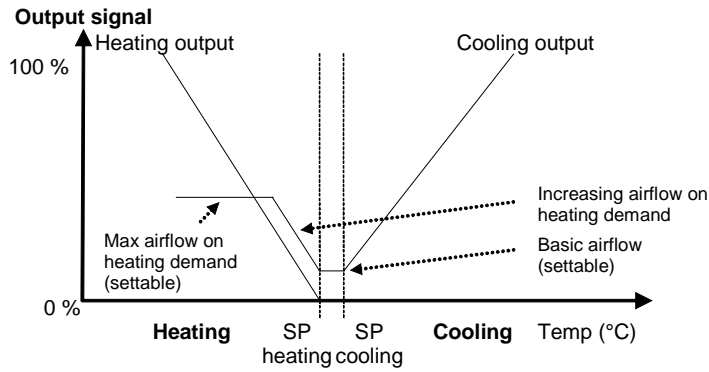

Cooling

In control state Cooling, the unit is always a cooling controller and controls according to the basic cooling setpoint plus the setpoint offset.

Cooling/Cooling

In control mode Cooling/Cooling, the controller always functions as a cooling controller and controls according to the basic cooling setpoint plus the setpoint offset. When the controller output signal reaches 50%, it is divided between two actuators. 0...48% of the signal is sent to actuator 1 and 52...100% of the signal is sent to actuator 2. See the figure below.

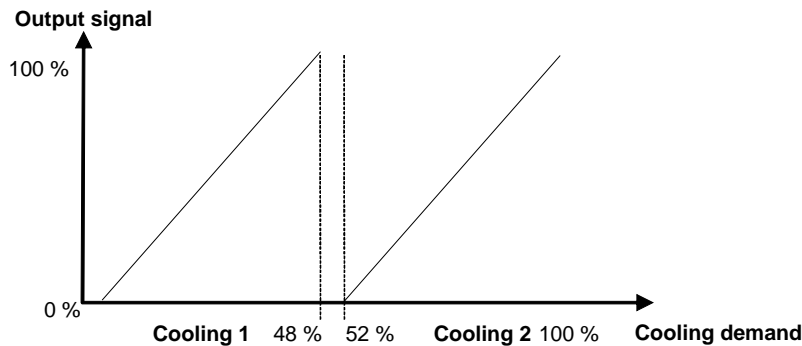

Heating/Cooling/VAV

This control mode is a Heating/Cooling control mode in which the cooling demand is split 50/50 between the cooling signal and the VAV signal.

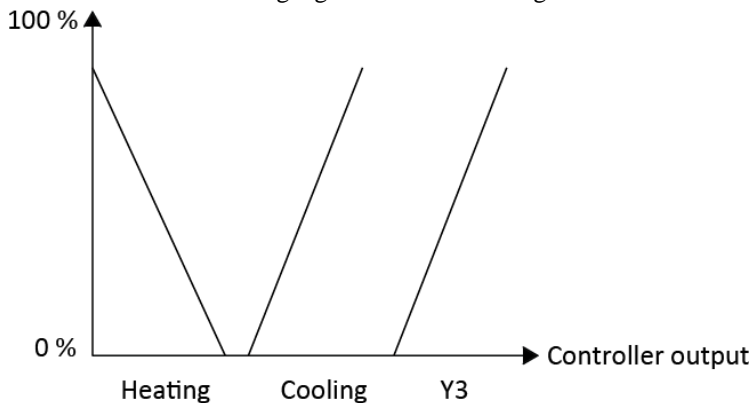

As the VAV signal may only be configured as an analogue output, this function is only available in models featuring analogue outputs (i.e. RCP200xx).

As the RCP200xx only has two analogue outputs and one of these is used by the VAV signal, it is necessary to configure either the cooling valve or heating valve as a thermal valve if additional valves are required.

Normal VAV functions apply to the VAV signal, i.e. if:

- A minimum flow function minimizes the opening of the VAV damper. The default setting is 20 %.
- CO₂ override is present. The default value for the VAV damper to start opening is 600 ppm, with 800 ppm required for it to open fully. The damper will open linearly between these values. The highest cooling and CO₂ demand will determine the damper output. The cooling output remains unaffected by the CO₂ control.
- Max. damper opening at heat demand is present. Default value for this is 0 %, but if set to e.g. 50 %, the VAV damper will open along with the heat signal until it reaches 50 %. This is used when the heater is placed in a duct where increased airflow is required as the heat demand increases. The highest demand from this function combined with the minimum airflow function determines the damper opening level at heat demand.

When forced ventilation is triggered, the VAV damper opens to 100 %. The cooling signal is unaffected by this action.

Reversed sequence

In some applications, e.g. when free cooling is available, it is possible to open the VAV damper prior to opening the cooling valve. This function works both with the digital function for forced ventilation, with an analog damper and with the Heating/Cooling/VAV control mode.

During Heating/Cooling/VAV control mode, the normal sequence is reversed so that, when the cooling signal is split, the VAV damper obtains the first 50 % and the cooling signal the second 50 %. The normal minimum flow VAV functionality, CO₂ control, etc. still function normally and only affect the VAV damper.

When digital forced ventilation is configured, the forced ventilation signal is set to a digital output when the temperature rises above the cooling setpoint. The signal is then returned as the temperature decreases below the cooling setpoint minus a set hysteresis (default 1°C).

Heating/Heating or Cooling via change-over

Models offering fan functionality have a function for controlling a heating coil on UO1 in sequence with change-over on UO2. When activated, the starting sequence of UO1/UO2 is changed together with the limits for fan start.

The change-over function will be used to switch between summer and winter mode. UO2 will be used as a cooling actuator in summer mode and as a heating actuator in winter mode.

In summer mode, Regio Maxi will function as a regular heating/cooling controller.

In winter mode it will function as a heating/heating controller. UO2 will initiate first, followed by UO1. The electrical heating coil connected to UO1 will start only if the ordinary heating coil on UO2 cannot meet the heating demand. When a heating demand exists, the output of UO2 is 0...100 % linear to the heating demand 0...48 % and UO1 0...100 % to the heating demand 52...100 %. When the heating demand is 48...52 % UO2 will always output 100 % and UO1 0 %.

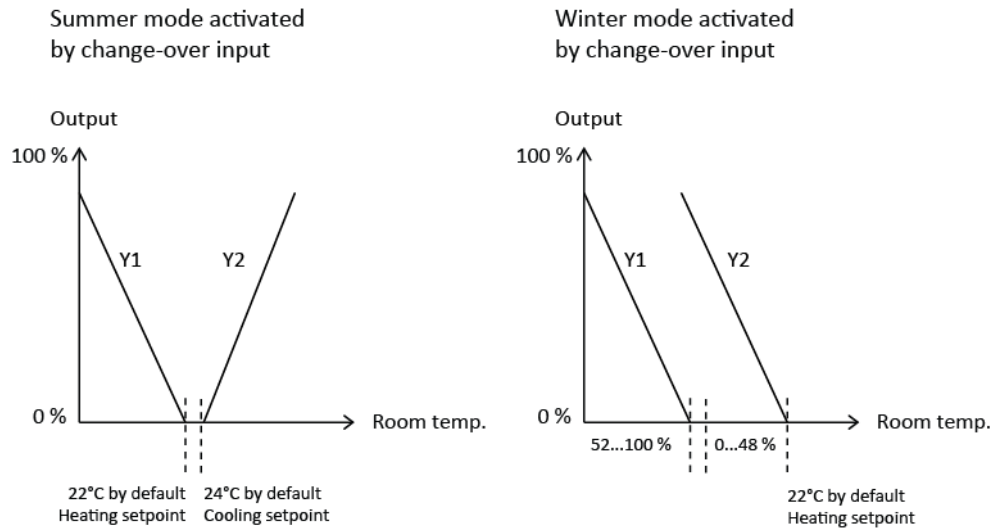

As the electrical heater is connected to UO1, and since an electrical heater may become very hot, a fan stop delay has been implemented into the system. The fan stop delay will only be activated when in heating mode, and then only if the fan has been running prior to the stop. When the heating output has been set to 0 %, the fan will continue to run for an additional 120 s, at the same speed it had prior to stopping.

Overheating risk

It is very important to note that Regio Maxi does not have any built-in function for monitoring when the fan is running or if the heating coil is overheating. This function must instead be provided by a supervisory system.

Additional features

Heating output min. limit

This function creates a minimum limit for the heating output which will activate when the controller enters heating mode. This function is mainly intended for use in heaters that are placed below large windows in order to avoid downdrafts resulting from insufficient heat demand. It is similar to the minimum limit used on the VAV damper in VAV control modes but has some difference in functionality.

When the function is active, the heating output never falls below the limit for as long as the controller remains in heating mode. If the controller enters cooling mode, the heating output will be closed. When the controller reenters heating mode, the heating output is reopened to its minimum level (this function is also present in all controller modes). Default setting for the output is 0 % (i.e. the function is inactive).

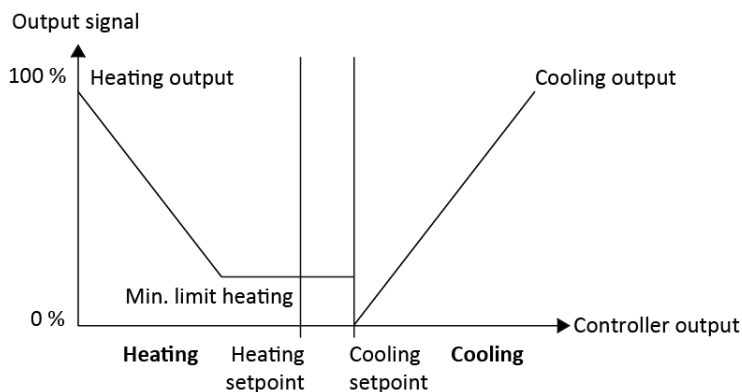

Different minimum flows for different operating modes

The different operating modes each have their own configuration for minimum flow in the VAV control modes. In “Off” the opening is set to 0 % as a default, while in “Unoccupied/Standby” it is set to 10 % and in “Occupied” to 20 %.

Chapter 8 Special functions

Change-over function

“Change-over” is a function for 2-pipe system installations. It enables using the same pipe for both heating and cooling, depending on the requirements during, for instance, summer (cooling output) and winter (heating output).

Control modes

To activate the change-over function, the control mode “Heating or cooling via change-over function” should be configured.

All controllers in the Regio series have an input for change-over. The input can be either an analogue PT1000 sensor or a closing contact connected to a digital input (FS = PT1000 input). The PT1000 sensor is mounted so that it senses the coil supply pipe temperature.

The change-over triggers based on the difference in temperature between the medium contained in the pipes and that of the room. When the temperature of the pipe medium is lower than the room temperature by 3 degrees (FS) the controller will change to cooling mode, and when the temperature of the pipe medium is higher than the room temperature by 4 degrees (FS) the controller will change to heating mode.

When using a digital signal input (potential-free contact), closing the contact switches the change-over function and sets the heating output to cooling. On open contact, the change-over function sets the heating output to heating.

There is also a parameter for setting the minimum valve exercise run-time at change-over.

It is also possible to control change-over via a central command. See the variable list in Part V of this manual.

Forced ventilation

All controllers in the Regio series have a digital output that can be configured for control of a forced ventilation damper to increase the airflow to the room. This output is always activated in the “Bypass” operating mode.

When the control state “Heating/Cooling with VAV control and forced supply air function” is active, the cooling output is used to control the forced ventilation damper. When forced ventilation is active, the cooling output is set to full cooling, regardless of what the controller output signal is.

Condensation detector

Special input CI

All Regio Maxi controllers have a special input (CI) intended for Regio’s condensation detector, KG-A/1 and which functions internally as a digital input, i.e. condensation or no condensation.

When the condensation detector is activated, cooling control is blocked and the controller is set into a neutral position. When condensation ceases, the controller will begin controlling from the neutral position.

CO₂ control

A CO₂ sensor can be connected to the controller in order to control the CO₂ level in the room. The CO₂ level can be used in different control modes to increase the quantity of air, regardless of the temperature requirements of the controller.

For example, when the the CO₂ level exceeds a set value the operating mode can be changed to forced ventilation or the VAV damper can be made to open.

Frost protection

Regio has built-in frost protection, which is activated when the controller is not in use (in Off mode). The frost protection prevents the temperature from dropping below 8°C. Return to normal fan speed and control occurs automatically when the room temperature exceeds 8°C.

Electrical heater

The function for handling an electrical heater is intended to work as a Heating/Cooling controller with the added ability to use support heating coming from an electrical heater. The function is based on Heating/Cooling control with change-over for the cooling output, while the heating output remains fixed to heating. The cooling output is connected to a water coil (or similar) with change-over capabilities.

During the cooling season, the controller operates as a heating/cooling controller with the coil in cooling mode and with the possibility of obtaining heat from the electrical heating coil if the temperature drops. The heating coil is connected to the heating output.

During the heating season, the change-over is set to heating mode and the cooling output operates a heat output to the coil. If the heat demand is greater than what can be supplied by the coil connected to the cooling output, the electrical heating coil connected to the heating output may be used to complement the coil connected to the cooling output. This means that, during heating season, the heat demand will be split 50/50 between the cooling and the heating outputs.

This means that:

- During the cooling season the controller works as a Heating/Cooling controller, with the cooling output connected to a water based (or similar) cooling coil and the heating output connected to an electrical heating coil.
- During the heating season the controller works as a Heating/Heating controller, with the cooling output connected to a water based (or similar) heating coil and the heating output connected to an electrical heating coil. The cooling output opens first, meaning that the water is used as a primary source of heat, followed by electrical heating if hot water is not enough.

The heating output and cooling output may be configured to an AO or DO respectively in any combination.

In the example below, the heating output is connected to AO1 and the cooling output to AO2.

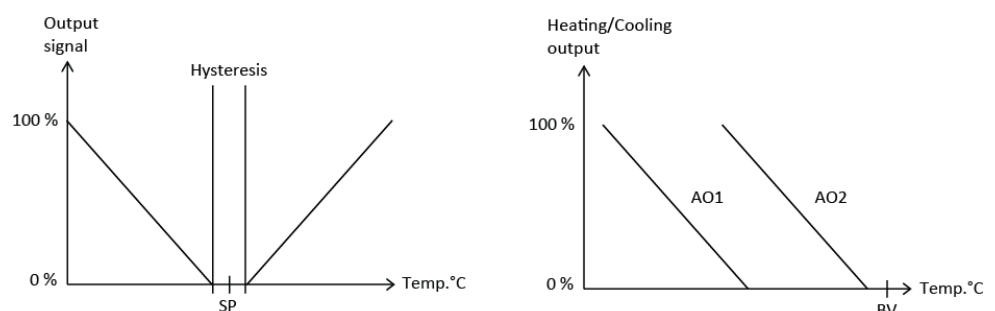

This function requires a fan, since the heating coil normally needs a fan in order not to overheat. As a result, this function is only available on the RCP100Fxx, and RCP200Fxx models. The function is present with both 3-speed fans and EC-fans.

To prevent the electrical heater from overheating, a fan stop delay is present. This delay works when the electrical heater has been activated and adds an additional 120 seconds of runtime when the fan normally should have stopped due to lack of heating demand.

To switch between heating and cooling mode, normal change-over functionality by AI or DI or manual setting applies.

Actuator exercise

All actuators are exercised. First, an opening signal is sent to the actuator for as long as the configured run time. Then a closing signal is sent for an equally long time after which the exercise is finished. It is possible to configure if the actuators should be exercised, on which day the exercise should take place and whether or not it should take place every day. It is also possible to configure at what time during the day the exercise should occur (FS=Every day at 3 pm).

Lighting control

The RCP-controllers can be used for controlling lighting. The lighting can be controlled in different ways:

- Manual control** The lighting can be controlled manually, either locally via the Select button on an RU-DOS unit or centrally via either a comprehensive SCADA system or Regio tool[®].
- Time control** Switch-on/switch-off times for each weekday can be configured locally in the controller. These times can be changed locally in the parameter menu in the display of RU-DOS or via Regio tool[®].
- Presence control** If the lighting is presence controlled, it is lit upon presence indication.
- Time/presence control** Time and presence control can be combined. The lighting is lit either when the local time channel is active or upon presence indication.

Blinds control

The controllers can also be used to control blinds via a digital output. The blinds can be controlled locally via the Select button or centrally via a comprehensive SCADA system or Regio tool[®].

Humidity sensor

By connecting a humidity sensor, the current relative humidity (% RH) in the room can also be measured. The value is shown locally in the display or via a central system.

Outdoor temperature sensor

It is also possible to connect a sensor that measures the current outdoor temperature. The value is shown locally in the display or via a central system.

Chapter 9 Fan control

In room units for fan control (RU-F-models) it is possible to control a fan at the following speeds: Off, Low speed, Medium speed, High speed and Auto. The fan speed in the Auto position depends on the controller output signal and the settings for each speed.

Fan speed control

Manual control

The fan can be manually controlled to run at any speed. On RU-models with display, the fan button is pressed once, resulting in a fan symbol being lit for 10 seconds in the display. As long as the symbol is lit, the fan speed can be changed using the INCREASE/DECREASE buttons. RU-models without display instead have a manual fan switch.



Figure 13. Fan button on room units with display



Figure 14. Fan switch on room units without display

The controller has the following fan positions:

- | | |
|-------------|---|
| Auto | Automatic control of the fan speed to maintain desired room temperature |
| 0 | Fan off |
| I | Manual position with low speed |
| II | Manual position with medium speed |
| III | Manual position with high speed |

Manual setting of speed I-III means that the speed of the fan in operating modes Stand-by, Occupied and Bypass always corresponds to the set speed. In the other operating modes, the fan is demand controlled.

Auto control

In auto mode, it is possible to configure whether the fan should be controlled by the heating output, the cooling output or by both the heating and cooling outputs. When the selected output exceeds the starting value set for each speed (FS for speed 1: 20 %, speed 2: 60 % and speed 3: 100 %), the fan is activated. It stops when the controller output signal drops below the set value minus the set hysteresis (FS = 5 %).

When the fan speed changes, there is always a minimum delay (2-3 s) as the output is deactivated for the current speed and activated for the new speed. Only one fan speed output is defined at a time.

Select button

For room units with a Select button it is also possible to set the maximum speed of the fan while it is in the auto position: “Auto 1”, “Auto 2” or “Auto 3”. “Auto 1” means that the maximum speed is 1, “Auto 2” that the maximum speed is 2 and so on.

Shutdown state	For room units with fan functionality (i.e. RU-xFx), the time before the unit enters shutdown state when the On/Off button is pressed down is 0s. This means that, by default, the unit will enter shutdown state immediately when the on/off button is pressed.
Off/Unoccupied	In operating modes Off and Unoccupied the fan is stopped regardless of the position of the fan switch or the setting in the display, on condition that the temperature is within the set temperature limits. If the temperature is not within the set temperature limits, the fan will be started in the corresponding Auto position regardless of other settings.
No fan stop	For fan models (RCP100Fx, RCP200Fx) there is a function to prevent the fan from stopping when the heating or cooling demand is 0. With the function activated, the fan will run at its lowest speed (1). This applies if the fan is in Auto mode and has been configured to run at the controller state (heating, cooling or both, parameter 50). This function is only available for the 3-speed fan function and only in operating modes Bypass, Occupied and Standby. If a window is opened, the fan will stop as usual.

EC fan control

The EC fan control works in a similar way to the 3-step fan control. The difference lays in the fact that the signal of the EC fan control uses an analogue output instead of 3 digital outputs. It is only available on RCP200xx models as it requires an analogue output to function. On the RCP200Fx models the EC fan function and the 3-step function run in parallel. This means that if an EC fan is configured on the analogue outputs, outputs DO1 – DO3 will be active (as they are not reconfigurable to anything else than fan speed) along with the analogue output.

The speed of the EC fan is determined by the heating and/or cooling demand. The default settings of the EC-fan follow the heating and cooling demand. I.e. if the heating or cooling demand is 55 % the fan runs at 55 %. The fan may be configured to follow both the heating and cooling demand, heating demand only, cooling demand only or no control at all.

Since a speed that is too low may damage the fan motor, there is a limit that the heating or cooling demand must pass before any signal is communicated to the controller. As a default, the setting is 10 % (1 V), meaning the fan will only start if the demand surpasses 10 %. A hysteresis is implemented (default setting 5 %), so that when the fan has started it will not stop until the demand has fallen below 5 %.

When using the control mode Heat/Cool/VAV (Split cool signal 50/50 with VAV), the fan speed signal follows that of the cooling signal.

A maximum speed may also be configured. If set to a lower value than 100 %, the fan will not exceed this limit.

Chapter 10 Operating modes

Different operating modes

The Regio controllers have the following operating modes:

- 0 = Off
- 1 = Unoccupied
- 2 = Stand-by
- 3 = Occupied (FS)
- 4 = Bypass

The operating modes can be controlled via the RU-unit or through a central command.

Off

Operating mode Off means that the controller is not heating or cooling, and the fans are stopped. However, the temperature may not drop below the set minimum temperature (FS=8°C). If it does, the controller will start heating, and (if a fan is used) start the fan whether it has been manually stopped or not.

For room units with display the background lighting is not lit, and only OFF is shown in the display.

Unoccupied

Operating mode Unoccupied means that the room where the controller is placed is not used for an extended period of time, for example during holidays or long weekends. Both heating and cooling are disconnected and the fans are stopped within a temperature interval with configurable min/max temperatures (FS min=15°C, max=30°C).

For room units with display the background lighting is not lit, but the current room temperature (or setpoint depending on the configuration) is shown in the display. OFF is also shown in the display.

Stand-by

Operating mode Stand-by means that the room is in an energy save mode and is not used at the moment. This can be during nights, weekends, evenings etc. The controller is prepared to change operating mode to Occupied (comfort) if someone enters the room (presence). The room temperature is controlled around the applicable heating and cooling setpoints, with an extended temperature interval (FS=+/-3°C). For example, if the heating setpoint=22°C and the cooling setpoint=24°C, the controller will allow the temperature in the room to be between 19°C and 27°C. The setpoints can also be adjusted +/- 3°C via the setpoint knob or the display of the room unit.

For room units with display the background lighting is lit (dimmed). STANDBY and the current room temperature (or setpoint depending on the configuration) are shown in the display.

Occupied

Operating mode Occupied means that the room is in use and is therefore in a comfort mode. The controller controls the room temperature around a heating setpoint and a cooling setpoint (FS heating setpoint=22°C, cooling setpoint=24°C). The setpoints can also be adjusted +/- 3°C locally via the setpoint knob or in the display of the room unit, or via a central command.

For room units with display the background lighting is lit (dimmed), and the occupancy indication is shown (see the chapter *Display handling*). The current room temperature (or setpoint depending on the configuration) is also shown in the display.

Bypass

Operating mode Bypass means that the room temperature is controlled the in the same way as in operating mode Occupied. The output for forced ventilation is also active. After a configurable time (FS=2 hours) in Bypass, the controller will normally return to the preset operating mode. However, if the parameter “Operating mode at presence detection” has been configured differently and presence is detected, it will return to this operating mode instead. Bypass is normally activated when the Occupancy button is pressed, via an occupancy detector or a central command. The operating mode is useful for example in conference rooms, where many people are present at the same time for a certain period of time.

For room units with display, the background lighting is lit (dimmed). The occupancy indication and the symbol for forced ventilation are shown (see the chapter *Display handling*). The current room temperature (or setpoint depending on the configuration) is shown in the display.

Activation of the different operating modes

Preset operating mode Occupied is the preset operating mode. On RU-models without display it can be changed to Stand-by via dipswitch SW3. OFF (FS): Occupied, ON: Stand-by. On RU-units with display, the preset operating mode is configured in the parameter menu in the display, parameter 45.

The operating mode is changed at the following events:

- When the Occupancy button is pressed (if the room unit has an Occupancy button).
- Activation/deactivation of an occupancy detector on a digital input.
- Via local time control in RCP.
- Via central control, for example central time control, central booking system etc.

Occupancy button

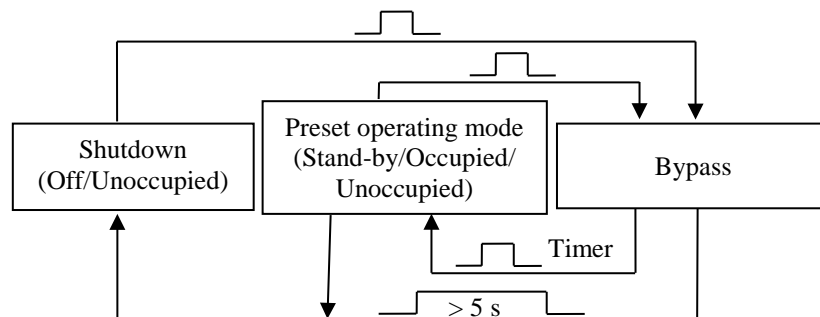

Shutdown

When the Occupancy button is held depressed for more than 5 seconds, the controller changes operating mode to "Shutdown" (Off/Unoccupied), regardless of the current operating mode. Via the display or Regio tool®, you can configure which operating mode, Off or Unoccupied, should be activated on "Shutdown". The factory setting is that Unoccupied is activated.

If you press the Occupancy button for less than 5 seconds when the controller is in operating mode Shutdown or the preset operating mode, the controller changes to operating mode Bypass. If you press the button for less than 5 seconds when the controller is in Bypass, it changes operating mode to the Preset operating mode.

After a configurable time in Bypass (FS=2 hours), the controller normally returns to the preset operating mode. However, if the parameter "Operating mode at presence detection" has been configured differently and presence is detected, it will return to this operating mode instead.

For handling of the Occupancy button in combination with local time control and central control, see the sections Local time control and Central control below.

For room units with fan functionality (i.e. RU-xFx), the time before the unit enters shutdown state when the On/Off button is pressed down is 0s. This means that, by default, the unit will enter shutdown state immediately when the on/off button is pressed.

Occupancy detector

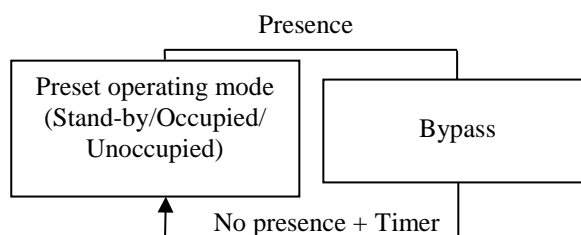

For local control of the operating mode between the preset operating mode and Bypass, an occupancy detector is connected.

When occupancy is indicated, the controller changes operating mode to Bypass or Occupancy as set in the parameter "Operating mode at presence detection". If you want to be able to enter the room temporarily without activating Bypass, for example to pick something up, you can configure a power-up delay. This means that Bypass is not activated until the power-up delay has expired. The Bypass delay can be set to a value between 0 and 60 minutes (FS=0 min).

In Bypass on presence, there is a switch-off timer, which means that if there is no occupancy indication during this time (FS=10 min), the controller will return to the preset operating mode.

Local time control

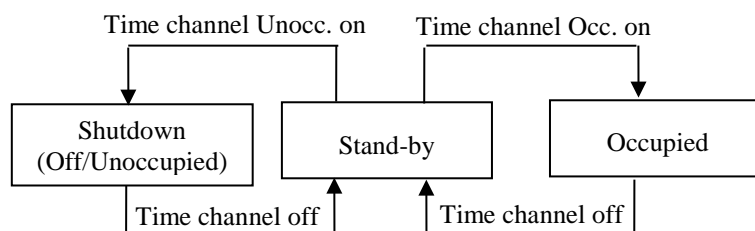

The Regio Maxi operating modes can be controlled using local time control. To accomplish this there are two time channels, one time channel Occupied for changing between Stand-by and Occupied, and one time channel Unoccupied for changing between Stand-by and Shutdown. If both time channels are active at the same time, the time channel for Occupied will take precedence.

The Occupancy button Pressing the Occupancy button overrides the local time control. I.e. if the controller is in Occupied mode and you press the Occupancy button, Bypass will be activated for 2 hours. The controller will then return to Occupied. If you press the Occupancy button again when the controller is in Bypass mode, Stand-by will be activated even if time channel Occupied is on.

If you press the Occupancy button when the controller is in Bypass and time channel Unoccupied is on, the controller will change to Shutdown instead of Stand-by.

When the Occupancy button is held depressed for more than 5 seconds, the controller changes operating mode to Shutdown, regardless of the time control.

Central control

Central control of the operating mode is also possible. By changing the variable **RegioRemoteState**, you can control the operating mode centrally according to the following table (there is a variable list for central control in Part V of this manual):

RegioRemoteState	Description
0	Central operating mode Off
1	Central operating mode Unoccupied
2	Central operating mode Stand-by
3	Central operating mode Occupied
4	(Not used)
5 (FS)	No central control

Table 9. The variable *RegioRemoteState*

The occupancy button When using central control (i.e. *RegioRemoteState* \neq 5) and you press the Occupancy button, the controller will change to Bypass and stay in this mode for as long time as you have configured. If you press the Occupancy button again when the controller is in Bypass, the controller will change to Stand-by, regardless of what has been set in the central control (*RegioRemoteState*).

When the controller is in Bypass and the Bypass time has run out, the controller will change to the operating mode given by **RegioRemoteState**. If **RegioRemoteState** equals 5 it will change to the preset operating mode.

If the controller is in Stand-by and the central control is changed, the controller will change to this new operating mode.

Occupancy detector

When central control is used and the occupancy detector is activated, the controller will go to Bypass for a configurable time, and thereafter return to the central operating mode.

Central command

Via central commands from a comprehensive system, for example EXOscada, you can handle the controller in the same way as you handle it locally via the Occupancy button, i.e. you can change its operating mode to Off/Unoccupied (Shutdown) or Bypass.

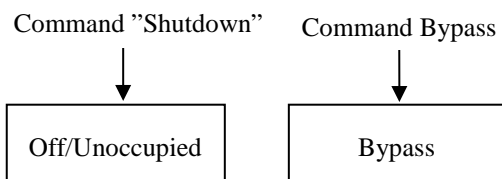

Central commands should be regarded as events and can be changed locally via the Occupancy button.

Chapter 11 Setpoint calculation

Basic setpoint

There are two basic setpoints, one basic heating setpoint (FS=22°C) and one basic cooling setpoint (FS=24°C). In RU-units with dipswitches for setting the basic setpoint (RU-units without display), the basic heating setpoint is set. The basic cooling setpoint is automatically changed at the same time. Therefore, the difference between the basic heating setpoint and the basic cooling setpoint is always the same.

Basic setpoint (°C)	SW1	SW2
20	OFF	OFF
22 (FS)	OFF	ON
24	ON	OFF
26	ON	ON

Table 10. Setting of basic heating setpoint with dipswitch SW1 and SW2

On RU-models with display, the basic setpoint is set in the display.

On all room units, you can also configure the setpoints via a central system or Regio tool[®]. When the model has dipswitches, the latest setpoint change will be valid.

Setpoint offset

The setpoint value can be adjusted up and down from the basic setpoint value, via the setpoint knob or the display in the RU-unit. How much the value can be adjusted can be configured in Regio tool[®] or in the parameter menu in the display (FS=+/-3°C).

In room units with display, you use the INCREASE button to increase the current setpoint in steps of 0.5°C to the max. limit, and the DECREASE button to decrease the current setpoint in steps of 0.5°C to the min. limit.

Calculation of the active setpoint

What setpoint value the controller should control according to depends on the operating mode, the control state and the current setpoint offset.

Off

In operating mode Off or on open window the controller is a heating controller and controls according to the frost protection setpoint (FS=8°C), regardless of the setpoint offset.

Unoccupied

In operating mode Unoccupied, it controls according to the heating setpoint (FS=15°C) or cooling setpoint (FS=30°C), depending on if a control mode with heating or cooling has been set. The active setpoint changes in the middle of the neutral zone with a hysteresis of 0.1°C. A setpoint offset is not active in this operating mode.

Stand-by

In operating mode Stand-by the controller controls according to the basic heating setpoint or the basic cooling setpoint plus/minus a settable neutral zone (FS=3°C). The setpoint can also be adjusted via the setpoint knob or display. This means that the factory setting for the heating setpoint is 19°C +/- 3°C (local displacement), and the factory setting for the cooling setpoint is 27°C +/- 3°C (local displacement). On heating demand the unit will control according to the heating setpoint, and on cooling demand it will control according to the cooling setpoint. The setpoint change takes place halfway between the setpoints with a hysteresis of 0.1°C.

Occupied/Bypass

In operating modes Occupied and Bypass the unit controls according to the basic heating setpoint or the basic cooling setpoint. The setpoint can also be adjusted via the setpoint knob or display. On heating demand it will control according to the heating setpoint, and on cooling demand it will control according to the cooling setpoint. The setpoint change takes place halfway between the setpoints with a hysteresis of 0.1°C.

Chapter 12 Actuators

Regio can be used with three types of actuators:

- Analogue 0...10 V actuators
- Thermal actuators
- 3-point actuators (Increase/Decrease actuators)

The actuator type is set via Regio tool[®].

Analogue actuators

The following output signals can be set for analogue actuators:

- 0...10 V (FS)
- 2...10 V
- 10...2 V
- 10...0 V

Thermal actuators

When thermal actuator control has been selected, this is controlled digitally with time proportional pulses via output UO.... By pulsing, the opening degree of the actuator (and its valve) is varied. The period time (in seconds) is the sum of the on and off output times on the output. The period time is FS=60s. The controller varies the on and off output times proportionally depending on the output signal demand to the actuator.

3-point actuators

For 3-point actuators (increase/decrease actuators), two digital outputs are used for controlling one actuator, one output to open the actuator and one to close it. You can configure the run time (in seconds) for the different actuators (FS=120 s). The program calculates the position of the actuator (0...100%) and sends an increase or decrease signal when the controller output signal deviates more than the set neutral zone (FS=2%) from the calculated position.

Chapter 13 Control via display

Display handling

The room units RU-DO, RU-DFO and RU-DOS have a built-in display.

These models also have an Occupancy button, as well as an INCREASE button and a DECREASE button to increase and decrease the setpoint.

The Select button on RU-DOS allows you to make more advanced settings and see more indications in the display (see the section *The Select button* below).

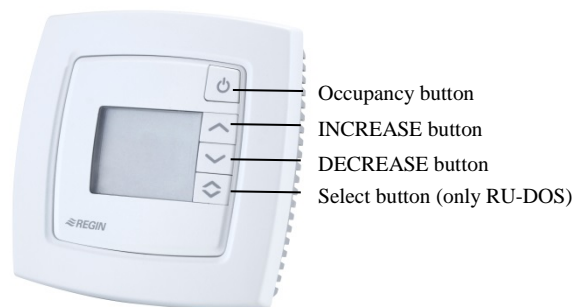

Figure 18. Buttons for display handling

Display indications

The display has the following indications (indications marked with an asterisk (*) are only available on RU-F-models):

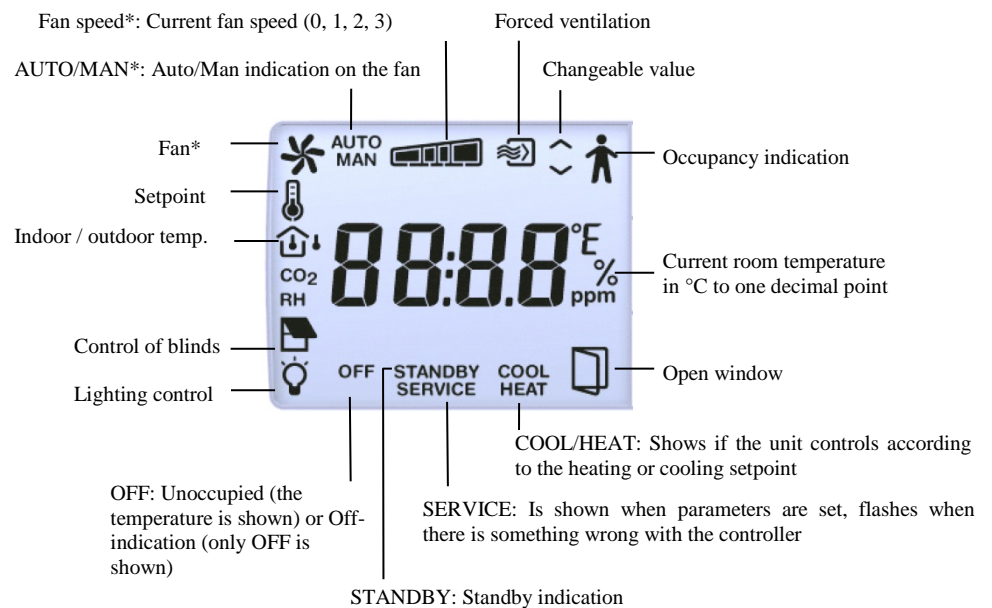

Figure 19. Indications in the display

RU-DOS features

The Select button

RU-DOS is a flexible room unit equipped with a special button which is called the Select button. Via this button some of the special functions in the Regio Maxi can be accessed and controlled.



Figure 17. RU-DOS

Pressing the Select button will alternate between the following indications:

- **Fan speed:** When this symbol is lit, the fan speed is changed using the INCREASE/DECREASE buttons.
- Current setpoint in °C to one decimal point and 0.5°C resolution.
- **Lighting control:** The lighting can be turned on/off using the INCREASE/DECREASE buttons.
- **Control of blinds:** The blinds can be controlled using the INCREASE/DECREASE buttons. The output for opening the blinds is active as long as the INCREASE button is depressed and the output for closing the blinds for as long as the DECREASE button is depressed.
- **CO₂:** Current percentage of CO₂ 0...9999 ppm.
- **RH:** Current humidity 0...100% RH.
- Current outdoor temperature in °C to one decimal point and 0.1°C resolution.

The parameter menu

In the RU-units with a display it is possible to change parameter values by using a parameter menu.

The parameter menu is accessed by simultaneously holding both the INCREASE and DECREASE buttons depressed for about 5 seconds until the “Service” indication is displayed. Next, press the INCREASE button twice.

The display will initially show parameter number 1. Scroll between parameters by using the INCREASE and DECREASE buttons.

Select

Press the Occupancy button to select the desired parameter. The parameter number will be replaced by the parameter value. The value can be changed using the INCREASE and DECREASE buttons. If a button is held depressed, the value will start scrolling, first slowly and then with increasing speed.

Acknowledge

To acknowledge and store a set parameter value, press the Occupancy button again. The display will then return to showing the parameter number. To retrieve the original value, i.e. the value before any changes took place, press the INCREASE and DECREASE buttons at the same time. The original value is then shown in the display.

Return

The display will return to the normal viewing mode from the parameter list in one of the following ways:

- After a predefined time, about 1 minute.
- When the INCREASE and DECREASE buttons are pressed simultaneously.
- By scrolling down to the end of the list so that “Exit” is shown in the display. The parameter menu is exited by pressing the Occupancy button while in Exit.

When in Exit, pressing INCREASE will move to the first parameter and pressing on DECREASE will move to the last parameter.

Parameter list

The following parameters can be changed in the parameter menu (FS = Factory setting):

Parameter number	Description	FS
1	Basic heating setpoint	22°C
2	Basic cooling setpoint	24°C
3	Neutral zone at Stand-by, Heating sp=Basic sp heating-3, Cooling sp=Basic sp cooling+3	3°C
4	Heating setpoint at Unoccupied	15°C
5	Cooling setpoint at Unoccupied	30°C
6	Frost protection setpoint	8°C
7	P-band for room controller	10°C
8	I-time (s) for room controller	300 s
9	The difference between the temperature in the room and the media temperature for change over to cooling.	3K
10	The difference between the temperature in the room and the media temperature for change over to heating.	4K
11	Controller mode: 0=Heat, 1= Heat / Heat, 2= Heat or Cool via change-over, 3= Heat / Cool, 4= Heat /Kyla with forced ventilation, 5= Heat / Kyla with VAV-control, 6= Cool, 7= Cool/Cool, 8= Heat / Cool with Y3 control (RCP-200xx models only), 9=Heat/Cool with change over for cooling (Not RCP-100)	3
12	Time in Bypass mode	120 min
13	Disconnect timer with occupancy/unoccupancy	10 min
14	Switch on delay for occupancy	0 min
15	State connected sensor on AI1: 0= None, 1=Room sensor, 2=Change-over, 3=Condensation detector, 4=Outdoor sensor, 5=CO ₂ , 6=Humidity sensor	1
16	State connected sensor on AI2: The same options as for AI1 (see above).	2
17	State connected sensor on DI1: 0=None, 1=Window contact, 2= Condensation detector, 3=Presence, 4=Change-over	3
18	State connected sensor on DI2: The same options as for DI1.	1
19	State connected sensor on DI3: The same options as for DI1.	2
20	State function of signal on AO1: 0=None, 1=Heating actuator, 2=Cooling actuator, 3=VAV-damper, 4=EC-control	1
21	State function of signal on AO2: 0=None, 1=Heating actuator, 2=Cooling actuator, 3=VAV-damper, 4=EC-control	2

Parameter number	Description	FS
22	State function of signal on DO1: 0=Ingen, 1=Fan speed 1, 2=Fan speed 2, 3=Fan speed 3, 4=Forced ventilation, 5=Thermal actuator heating, 6=Thermal actuator cooling, 7=Heating actuator increase, 8=Heating actuator decrease, 9=Cooling actuator increase, 10=Cooling actuator decrease, 11=Lighting, 12=Control of blinds open, 13=Control of blinds close	RCP100=4 RCP200=4 RCP100-F=1 RCP200-F=1
23	State function of signal on DO2: The same options as for DO1.	RCP100=0 RCP200=0 RCP100-F=2 RCP200-F=2
24	State function of signal on DO3: The same options as for DO1.	RCP100=5 RCP200=0 RCP100-F=3 RCP200-F=3
25	State function of signal on DO4: The same options as for DO1.	RCP100=6 RCP200=0 RCP100-F=4 RCP200-F=4
26	State function of signal on DO5: The same options as for DO1.	RCP100=0 RCP200=0 RCP100-F=0 RCP200-F=0
27	State function of signal on DO6: The same options as for DO1.	RCP100=0 RCP200=0 RCP100-F=5 RCP200-F=0
28	State function of signal on DO7: The same options as for DO1.	RCP100=0 RCP200=0 RCP100-F=6 RCP200-F=0
29	State type of heating actuator: 0=0...10V, 1=2...10V, 2=10...2V, 3=10...0V	0
30	State type of cooling actuator: 0=0...10V, 1=2...10V, 2=10...2V, 3=10...0V	0
31	Period time for heating actuator with thermal actuator	60 s
32	Period time for cooling actuator with thermal actuator	60 s
33	Run time for heating actuator with increase/decrease actuator	120 s
34	Run time for cooling actuator with increase/decrease actuator	120 s
35	Neutral zone for increase/decrease actuator	2%
36	Day for exercise of heating actuator 0=never, 1-7=Mon-Sun, 8=every day	8
37	Day for exercise of cooling actuator 0=never, 1-7=Mon-Sun, 8=every day	8
38	Hour for exercise of heating actuator	15
39	Hour for exercise of cooling actuator	15
40	Minute for exercise of heating actuator	0
41	Minute for exercise of cooling actuator	0
42	Select if setpoint or actual value is to be shown on display, 0=Actual, 1=Heating setpoint, 2=Cooling setpoint, 3=Average value of heating and cooling setpoint, 4=Only setpoint offset	0
43	Highest permitted setpoint offset upwards	3°C
44	Highest permitted setpoint offset downwards	3°C
45	Preset operating mode: 0=Off, 1=Unoccupied, 2=Stand-by, 3=Occupied. Forced ventilation is not set in Occupied mode.	3

Parameter number	Description	FS
46	State operating mode by depressing Occupancy button for 5 sec: 0=Off, 1=Unoccupied, 2=Stand-by, 3=Occupied. Forced ventilation is not set in Occupied mode.	1
47	Select operating mode for central control: 0=Off, 1=Unoccupied, 2=Stand-by, 3=Occupied, 5=No central control	5
48	Min flow at cooling output when control state Heat/cool with VAV-control or heat/cool/VAV is selected	20
49	Max flow at cooling output when control state Heat/cool with VAV-control is selected and heating is applied	0
50	Configuration of fan control: 0=No control, 1=The fan is controlled by heating requirement, 2=The fan is controlled by cooling requirement, 3=The fan is controlled by heating and cooling requirement	3
51	Start signal in % for fan speed 1 on heating or cooling control	20
52	Start signal in % for fan speed 2	60
53	Start signal in % for fan speed 3	100
54	Hysteresis for start/stop of fans	5
55	State number of speeds for fan	3
56	Temperature compensation on AII	0°C
57	Temperature compensation on UII	0°C
58	Temperature compensation for internal room sensor	0°C
59	Filter factor for analogue temperature inputs	0.2
60	State NO/NC digital input 1 0=NO (Normally open), 1=NC (Normally closed)	0
61	State NO/NC digital input 2 0=NO (Normally open), 1=NC (Normally closed)	1
62	State NO/NC digital input 3 0=NO (Normally open), 1=NC (Normally closed)	0
63	Manual/Auto heating output signal: 0=Off, 1=Manual, 2=Auto	2
64	Manual/Auto cooling output signal: 0=Off, 1=Manual, 2=Auto	2
65	Manual/Auto forced ventilation: 0=Off, 1=On, 2=Auto. Can e.g. be activated from a central system for e.g. night cooling	2
66	Manual/Auto control of change-over mode: 0=Heating control, 1=Cooling control, 2=Automatic change-over depending on analogue temperature sensor or digital input	2
67	Heating output signal in manual mode	0
68	Cooling output signal in manual mode	0
69	Controller Modbus address	254
70	Parity bit Modbus communication: 0=No parity, 1=Odd parity, 2=Even parity	2
72	Modbus communication speed: 0=9600, 1=4800, 2=2400 etc. 15=19200	0
73	Activate Modbus as default in Regio Maxi: 0=Off, 1=On	0
74	Selection of heating output function (NO/NC): 0=NC, 1=NO	0
75	Setpoint display at setpoint adjustment.: 0=The offset is shown in the display, 1=The active setpoint + offset is shown in the display. Heat or Cool is shown depending on whether heat or cool is active when entering the menu, 2=Heat setpoint + offset is shown in the display, 3=Cooling setpoint + offset is shown in the display	0
76	Forced ventilation, control function: 0=Not active, 1=Forced ventilation at 100% output of heat or cool, 2=Forced ventilation at 100% cooling output.	0
77	Operating mode at presence detection (DII): 3=Occupied, 4=Bypass	4
78	EXOline PLA-address	FS
79	EXOline ELA-address	FS
84	Minimum runtime when calculating for change over	600 s

Parameter number	Description	FS
85	Alarm hysteresis	0.2
86	Alarm limit high room temperature	40
87	Alarm limit low room temperature	15
88	Max room temperature deviation	20
89	Alarm limit high condensation	80
90	Hysteresis condensation alarm	2
91	Activate the logging function for EXOscada	1
92	Activate alarms and events for EXOscada (0=Not active, 1=Only alarms, 2=Only events, 3=Both alarms and events active)	3
93	Enable automatic switch between summer time and normal time	1
94	State function for lighting control 0=Manual control, 1=Time control, 2=Presence control, 3=Time and presence control	0
95	Manual control of the lighting	0
96	Activate presence if the percentage of CO ₂ is high	0
97	Activate presence if CO ₂ is higher	800
98	Deactivate presence if CO ₂ is below the limit value minus this hysteresis	160
99	Filter factor for the condensation input	0.2
100	Filter factor for CO ₂ -input	0.2
101	Filter factor for RH-input	0.2
102	Condensation at 0V	0
103	Condensation at 10V	100
104	CO ₂ at 0V	0
105	CO ₂ at 10V	1000
106	RH at 0V	0
107	RH at 10V	100
108	Command for taking the blinds in	0
109	Command for taking the blinds out	0
110	Run time for controlling the blinds in/out	240
111	Activate condensation detector on the CI-input 0=Not active, 2=Condensation detector active	2
112	Min limit for VAV-damper at CO ₂ -control	600
113	Max limit for VAV-damper at CO ₂ -control	800
114	State output signal range for VAV damper actuators: 0=0...10V, 1=2...10V, 2=10...2V, 3=10...0V	0
115	Manual/Auto VAV damper output: 0=Off, 1=Manual, 2=Auto	2
116	VAV damper output in manual mode	0
117	Sequence order for Y2 and Y3. 0=Y2 activates before Y3, 1=Y3 activates before Y2	0
118	Minimum flow at cool output at control state Standby when controller mode heat/cool with VAV-control or Heat/cool/VAV is selected	10
119	Minimum flow at cool output at control state Unoccupied when controller mode heat/cool with VAV-control or Heat/cool/VAV is selected	10
120	Minimum flow at cool output at control state Off when controller mode heat/cool with VAV-control or Heat/cool/VAV is selected	0
121	Min limit for EC-fan (V)	1.0
122	Max limit for EC-fan (V)	10
123	The fan will never stop (0=OFF, 1=ON)	0
124	Minimum limit for the heat output	0%
130	The controller's current time (second)	
131	The controller's current time (minute)	
132	The controller's current time (hour)	

Parameter number	Description	FS
133	The controller's current time (weekday)	
134	The controller's current time (week number)	
135	The controller's current time (date)	
136	The controller's current time (month)	
137	The controller's current time (year)	
138	Start time Monday Occupied	0
139	Start time Tuesday	0
140	Start time Wednesday	0
141	Start time Thursday	0
142	Start time Friday	0
143	Start time Saturday	0
144	Start time Sunday	0
145	Start time holidays	0
146	Stop time Monday	0
147	Stop time Tuesday	0
148	Stop time Wednesday	0
149	Stop time Thursday	0
150	Stop time Friday	0
151	Stop time Saturday	0
152	Stop time Sunday	0
153	Stop time holidays	0
154	Start time 2 Monday Occupied	0
155	Start time Tuesday	0
156	Start time Wednesday	0
157	Start time Thursday	0
158	Start time Friday	0
159	Start time Saturday	0
160	Start time Sunday	0
161	Start time holidays	0
162	Stop time Monday	0
163	Stop time Tuesday	0
164	Stop time Wednesday	0
165	Stop time Thursday	0
166	Stop time Friday	0
167	Stop time Saturday	0
168	Stop time Sunday	0
169	Stop time holidays	0
170	Start time 1 Monday Unoccupied	0
171	Start time Tuesday	0
172	Start time Wednesday	0
173	Start time Thursday	0
174	Start time Friday	0
175	Start time Saturday	0
176	Start time Sunday	0
177	Start time holidays	0
178	Stop time 1 Monday Unoccupied	0
179	Stop time Tuesday	0
180	Stop time Wednesday	0
181	Stop time Thursday	0
182	Stop time Friday	0
183	Stop time Saturday	0
184	Stop time Sunday	0

Parameter number	Description	FS
185	Stop time holidays	0
186	Start time 2 Monday Unoccupied	0
187	Start time Tuesday	0
188	Start time Wednesday	0
189	Start time Thursday	0
190	Start time Friday	0
191	Start time Saturday	0
192	Start time Sunday	0
193	Start time holidays	0
194	Stop time 2 Monday Unoccupied	0
195	Stop time Tuesday	0
196	Stop time Wednesday	0
197	Stop time Thursday	0
198	Stop time Friday	0
199	Stop time Saturday	0
200	Stop time Sunday	0
201	Stop time holidays	0
202	Start time 1 Monday Lighting	0
203	Start time Tuesday	0
204	Start time Wednesday	0
205	Start time Thursday	0
206	Start time Friday	0
207	Start time Saturday	0
208	Start time Sunday	0
209	Start time holidays	0
210	Stop time 1 Monday Lighting	0
211	Stop time Tuesday	0
212	Stop time Wednesday	0
213	Stop time Thursday	0
214	Stop time Friday	0
215	Stop time Saturday	0
216	Stop time Sunday	0
217	Stop time holidays	0
218	Start time 2 Monday Lighting	0
219	Start time Tuesday	0
220	Start time Wednesday	0
221	Start time Thursday	0
222	Start time Friday	0
223	Start time Saturday	0
224	Start time Sunday	0
225	Start time holidays	0
226	Stop time 2 Monday Lighting	0
227	Stop time Tuesday	0
228	Stop time Wednesday	0
229	Stop time Thursday	0
230	Stop time Friday	0
231	Stop time Saturday	0
232	Stop time Sunday	0
233	Stop time holidays	0
234	Start date holiday 1	1.01
235	Start date holiday 2	1.01
236	Start date holiday 3	1.01

Parameter number	Description	FS
237	Start date holiday 4	1.01
238	Start date holiday 5	1.01
239	Start date holiday 6	1.01
240	Start date holiday 7	1.01
241	Start date holiday 8	1.01
242	Start date holiday 9	1.01
243	Start date holiday 10	1.01
244	Stop date holiday 1	1.01
245	Stop date holiday 2	1.01
246	Stop date holiday 3	1.01
247	Stop date holiday 4	1.01
248	Stop date holiday 5	1.01
249	Stop date holiday 6	1.01
250	Stop date holiday 7	1.01
251	Stop date holiday 8	1.01
252	Stop date holiday 9	1.01
253	Stop date holiday 10	1.01

Table 12. Parameter list

Chapter 14 Status indications

Indications on the RU-units

LED

All room units without display have a LED shaped like a thermometer on the front. A red indication is shown when heating control is functional and a blue indication is shown when cooling control is active. When there is something wrong with the controller, the LED flashes red and blue.



Figure 15. The LED

The occupancy button On room units without display, the occupancy button has the following indications:

- Occupied: Fixed green indication
- Standby: Flashing green indication
- Bypass: Fixed green indication with a short flash
- Off and Unoccupied: No indication



Figure 16. The occupancy button

For RU-models with display, these indications are shown in the display, see the chapter *Display handling*.

Communication LED

When the frame of the room units has been removed, a LED is visible in the right edge of the controller. It lights up green when the controller is sending information.

Indications on the RCP-units

Adjacent to terminals 40-43 and 80, there are a number of LED:s which indicate status.



Figure 17. LED:s on RCP

Designation	Colour	Description
P/B (Power supply/Battery)	Green/Red	Power supply on/Battery error
Lan/Serv	Green/Yellow	For TCP/IP status indication
Rx	Green	Port 1, Receiving
Tx	Green	Port 1, Transmitting
RURX	Green	Port RU, Receiving

Table 11. The function of the LED:s

Chapter 15 Maintenance and service

Changing the battery

Note! This procedure requires knowledge of proper ESD protection; i.e. an earthed wristband must be used. How to lift off the cover is described in the section *Removing the cover* below.

When the battery LED on the RCP is lit, the battery for backup of program memory has become too weak. Replace the battery as described below. A backup capacitor saves the memory for at least 10 minutes after the power supply has been removed. Thus, if battery replacement takes less than 10 minutes there will be no need to reload the program.

The replacement battery must be of the type CR2032.

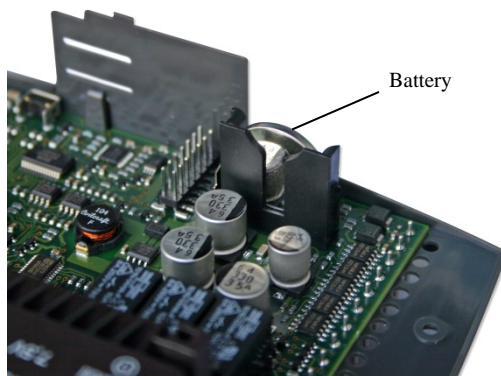

Figure 20. The position of the battery

Grip the battery firmly with your fingers and lift it upwards until it rises from its holder. Press the new battery firmly down into place. Note that to preserve correct polarity, the battery can only be inserted the “right way round”.

Updating EXOreal

Note! This procedure may only be carried out by qualified resellers and requires advanced knowledge.

The operation system is updated from the RS485 port. Use EXOdesigner.

Resetting the application memory

Note! This procedure may only be carried out by qualified resellers and requires advanced knowledge. The application program will be permanently lost after this procedure.

The processor's program memory (application program) is reset via the reset button in the small hole on the right side of the unit. You can for example use a paper-clip to access the reset button.



Figure 21. Resetting the program memory via the reset button

Removing the cover

Note! This procedure requires knowledge of proper ESD protection; i.e. an earthed wristband must be used.

Remove the cover according to figure 22, using a Torx 7.



Figure 22.

Signals

Table of contents

Part V Signals and variables

CHAPTER 16 SIGNAL TYPES	84
CHAPTER 17 MODBUS SIGNALS	86
DISCRETE INPUT REGISTER	86
COIL STATUS REGISTER	87
INPUT REGISTER.....	88
HOLDING REGISTER.....	90
CHAPTER 18 LONWORKS NETWORK VARIABLES	101

Chapter 16 Signal types

EXOL type

The EXOL type of the signals:

R = Real (-3.3E38 - 3.3E38)

I = Integer (-32768 - 32767)

X = Index (0 - 255)

L = Logic (0/1)

Modbus type

The Modbus type of the signals (type in the list below):

1 = Coil Status Register (Modbus function = 1, 5 and 15)

2 = Input Status Register (Modbus function = 2)

3 = Holding Register (Modbus function = 3, 6 and 16)

4 = Input Register (Modbus function = 4)

Supported Modbus functions:

1 = Read Coils

2 = Read Discrete Input

3 = Read Holding Register

4 = Read Input Register

5 = Write Single Coil

6 = Write Single Register

15 = Write Multiple Coils

16 = Write Multiple Registers

Max 47 register

Max 47 register can be read in one message.

Communication limits

The modbus master must wait for a minimum of 3.5 character times (4ms at 9600 bps) between two messages. When the modbus master communicate with more than one controller on the same communication line (RS485), the modbus master must wait for a minimum of 14 character times (16ms at 9600bps) between the answer and the first question for the next controller.

In the controller there is a limit of 10 fast communications in every half minute, the other communications will have a delayed answer of approximately 1 second.

Scale factor Modbus

All real signals have scale factor 10 except the time settings signals that have scale factor 100 for modbus communication. Integer, Index and Logic has always scale factor 1.

EXOline/Modbus

The factory setting for the Maxi controller is Modbus communication. If you try to communicate EXOline, the controller will automatically change to EXOline communication after the first communication attempt. 10 seconds after the last EXOline communication, the controller will return to Modbus communication. You can also set the controller to only communicate EXOline, via Regio tool[®] or a parameter in the display.

Modbus wiring etc.

A protocol such as Modbus consists of several layers (OSI-model). The bottom layer is always the physical layer, number of wires and signal levels. the next layer describes the communication digits (number of data bits, stop-bits, parity etc). Then come the layers describing the Modbus specific functions (number of digits per message, the meaning of different messages etc). For Modbus, the bottom layer can be RS485, RS422 or RS232.

RS485 contra RS422

RS485 and RS422 are the electric part of the protocol, i.e. the physical layer. RS485 has two connections, A and B. Often there is also a protective earth (N on EXOmodules). RS485 units are always connected A → A and B → B. RS485 is so called half duplex communication: Communication can only go in one direction at a time; i.e. the master will first send an enquiry and will thereafter listen for the reply. A and B are used for both transmission and reception.

RS422 is a full duplex communication which means you need 4 wires, 2 for transmit (Tx+ and Tx-) and 2 for receive (Rx+ and Rx-). Tx is used to transmit and Rx to receive which means that Tx in one unit must be connected to Rx in the other and vice versa. As for signal levels etc. RS422 and RS485 are identical.

To interconnect RS485 and RS422: On the RS422 unit connect Tx+ with Rx+ and Tx- with Rx-. We have now changed a 4-wire system to a 2-wire system and can connect them to A and B on the RS485 unit. Which goes where is something you most often need to find out by trial and error. Incorrect polarity will just give nonfunction but cannot harm either unit.

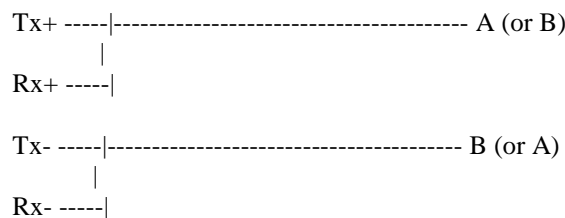

Bitrate, two stop bits, parity is the next layer.

These settings must correspond to the settings in the master unit. Find out how the master is set and then give the Controller the same settings.

Parity can be set to odd, even or none. If odd or even is chosen only one stop-bit is used otherwise there will be too many bits altogether: 1 start-bit, 8 data-bits, 1 parity-bit and 1 stop-bit give a total of 11 bits which is maximum. Note that if the parity is set to “none”, only one stop bit will be used.

LonWorks

Models with LON communication have a communication port for LonWorks. Connection to the network is established using the programming tool LonMaker. The xif-file is available for download from Regin’s homepage. Network variables for LON can be found at the end of Chapter 18 .

Chapter 17 Modbus signals

Discrete Input Register

Signal name	Type	Modbus address	Default value	Description
RCPActual.RegioDigIn(0)	L,2	1		Not used
RCPActual.RegioDigIn1	L,2	2		Value of digital input 1.
RCPActual.RegioDigIn2	L,2	3		Value of digital input 2.
RCPActual.RegioDigIn3	L,2	4		Value of digital input 3.
RCPActual.RegioDigOut(0)	L,2	5		Not used
RCPActual.RegioDigOut1	L,2	6		Value of digital output 1.
RCPActual.RegioDigOut2	L,2	7		Value of digital output 2.
RCPActual.RegioDigOut3	L,2	8		Value of digital output 3.
RCPActual.RegioDigOut4	L,2	9		Value of digital output 4.
RCPActual.RegioDigOut5	L,2	10		Value of digital output 5.
RCPActual.RegioDigOut6	L,2	11		Value of digital output 6.
RCPActual.RegioDigOut7	L,2	12		Value of digital output 7.
RCPActual.RegioDIOpenWindow	L,2	13		Indicate open window
RCPActual.RegioDICondensationAlarm	L,2	14		Indicate condensation alarm from digital input
RCPActual.RegioDIPresences	L,2	15		Indicate presence from digital input
RCPActual.RegioDIChangeOver	L,2	16		Indicate change over from digital input
RCPActual.RegioFanSpeed1	L,2	17		Indicate fan speed 1
RCPActual.RegioFanSpeed2	L,2	18		Indicate fan speed 2
RCPActual.RegioFanSpeed3	L,2	19		Indicate fan speed 3
RCPActual.RegioForcedventilation	L,2	20		Indicate forced ventilation
RCPActual.RegioCVHeatPulsProp	L,2	21		Indicate puls prop heating
RCPActual.RegioCVCoolPulsProp	L,2	22		Indicate puls prop cooling
RCPActual.RegioCVHeatInc	L,2	23		Indicate increase heating
RCPActual.RegioCVHeatDec	L,2	24		Indicate decrease heating
RCPActual.RegioCVCoolInc	L,2	25		Indicate increase cooling
RCPActual.RegioCVCoolDec	L,2	26		Indicate decrease cooling
RCPActual.RegioAIChangeOverState	L,2	27		Indicate change over state from analog input
RCPActual.RegioChangeOverState	L,2	28		Indicate change over state from both digital and analog input
RCPActual.RegioRoomTempSensorAlarm	L,2	29		Indicate sensor alarm on room sensor
RCPInternal.RegioNotUsedL	L,2	30		Not used
RCPInternal.RegioNotUsedL	L,2	31		Not used
RCPInternal.RegioNotUsedL	L,2	32		Not used

Signal name	Type	Modbus address	Default value	Description
RCPInternal.RegioNotUsedL	L,2	33		Not used
RCPInternal.RegioNotUsedL	L,2	34		Not used
RCPInternal.RegioNotUsedL	L,2	35		Not used
RCPInternal.RegioNotUsedL	L,2	36		Not used
RCPActual.RegioCIn	L,2	37		Value of condensation input.
RCPActual.RegioLighting	L,2	38		Indicate lightning is on
RCPActual.RegioSumAlarm	L,2	39		Indicate sum alarm
RCPActual.RegioJalusi	L,2	40		Indicate jalusi is out
RCPActual.RegioCO2Presence	L,2	41		Indicate presence from CO ₂ sensor
RCPActual.RegioTGOccupied	L,2	42		Is set if timechannel Occupied is active
RCPActual.RegioTGUnOccupied	L,2	43		Is set if timechannel Unoccupied is active
RCPActual.RegioTGLighting	L,2	44		Is set if timechannel lightning is active
RCPActual.RegioAlaPt(1)	L,2	45		Indicate presence
RCPActual.RegioAlaPt(2)	L,2	46		Indicate Open window
RCPActual.RegioAlaPt(3)	L,2	47		Condensation alarm
RCPActual.RegioAlaPt(4)	L,2	48		Room temp high
RCPActual.RegioAlaPt(5)	L,2	49		Room temp low
RCPActual.RegioAlaPt(6)	L,2	50		Room temp deviation
RCPActual.RegioAlaPt(7)	L,2	51		Room controller in manual mode
RCPActual.RegioAlaPt(8)	L,2	52		Sensor alarm

Coil Status Register

Signal name	Type	Modbus address	Default value	Description
RCPSettings.RegioBypass	L,1	1	0	Force the unit in Bypass mode. Is automatically returned after Bypass time (default=120 min)
RCPSettings.RegioShutDown	L,1	2	0	Force the unit in ShutDown state
RCPInternal.RegioNotUsedL	L,1	3	0	Not used
RCPSettings.RegioDiNC(0)	L,1	4	0	Not used
RCPSettings.RegioDi1NC	L,1	5	0	Normally open (NO) or normally closed (NC) on digital input 1. 0=NO, 1=NC.
RCPSettings.RegioDi2NC	L,1	6	1	Normally open (NO) or normally closed (NC) on digital input 2. 0=NO, 1=NC.
RCPSettings.RegioDi3NC	L,1	7	0	Normally open (NO) or normally closed (NC) on digital input 3. 0=NO, 1=NC.
RCPSettings.RegioCVHeatPulsPropNC	L,1	8	0	Selection of heating output function (NO/NC): 0=NC, 1=NO

Signal name	Type	Modbus address	Default value	Description
RCPSettings.RegioMinFanSpeed	L,1	9	0	The fan will never stop: 0=Off 1=On
RCPInternal.RegioNotUsedL	L,1	10	0	Not used
RCPSettings.RegioLogActive	L,1	11	1	Activate logging function for EXOscada
RCPSettings.RegioAutoSummerTime	L,1	12	1	Enable automatic switch between summer time and normal time. 0=Off, 1=On
RCPSettings.RegioLightManual	L,1	13	0	Control the light in manual mode.
RCPSettings.RegioCO2Function	L,1	14	0	Activate presence on CO2 sensor.
RCPSettings.RegioJalusiInCmd	L,1	15	0	Command jalusi in.
RCPSettings.RegioJalusiOutCmd	L,1	16	0	Command jalusi out
RCPSettings.RegioModbusComm	L,1	17	1	Activate modbus communication

Input Register

Signal name	Type	Modbus address	Default value	Description
RCPActual.RegioSoftware	X,4	1		Type of Regio software: 0 = RCP 1 = RC
RCPActual.RegioVerMajor	X,4	2		Major version
RCPActual.RegioVerMinor	X,4	3		Minor version
RCPActual.RegioVerBranch	X,4	4		Branch version
RCPActual.RegioRevision	X,4	5		Revision
RCPInternal.RegioNotUsedX	X,4	6		Not used
RCPActual.RegioUnitState	X,4	7		Indicate current unit state: 0 = Off 1 = Unoccupied 2 = Stand-by 3 = Occupied 4 = ByPass
RCPActual.RegioControllerState	X,4	8		Indicate current controller state: 0 = Off 1 = Heating 2 = Cooling
RCPActual.RegioFanSpeed	X,4	9		Indicate current fan speed: 0 = Off 1 = Fan speed 1 is on 2 = Fan speed 2 is on 3 = Fan speed 3 is on
RCPInternal.RegioNotUsedX	X,4	10		Not used
RCPActual.RegioRoomTemp	R,4	11		Room temperature
RCPActual.RegioRoomTempExt	R,4	12		Room temperature from external sensor
RCPActual.RegioRoomTempInt	R,4	13		Room temperature from internal sensor

Signal name	Type	Modbus address	Default value	Description
RCPActual.RegioAIChangeOver	R,4	14		Change over temperature
RCPActual.RegioAnaIn1	R,4	15		Value of analog input 1
RCPActual.RegioAnaIn2	R,4	16		Value of analog input 2
RCPActual.RegioAnaOut1	R,4	17		Value of analog output 1
RCPActual.RegioAnaOut2	R,4	18		Value of analog output 2
RCPActual.RegioSetPAdjustment	R,4	19		Setpoint adjustment from internal device
RCPActual.RegioPIDSetP	R,4	20		The controller setpoint
RCPActual.RegioPIDOutput	R,4	21		The controller output (0-100%)
RCPActual.RegioHeatOutput	R,4	22		Heat output (0-100%)
RCPActual.RegioCoolOutput	R,4	23		Cool output (0-100%)
RCPInternal.RegioNotUsedX	X,4	24		Not used
RCPInternal.RegioNotUsedX	X,4	25		Not used
RCPInternal.RegioNotUsedX	X,4	26		Not used
RCPInternal.RegioNotUsedX	X,4	27		Not used
RCPInternal.RegioNotUsedX	X,4	28		Not used
RCPInternal.RegioNotUsedX	X,4	29		Not used
RCPActual.RegioOutDoorTemp	R,4	30		Outdoor temperature
RCPActual.RegioCondensation	R,4	31		Condensation input value (%)
RCPActual.RegioRoomCO2	R,4	32		CO ₂ input value (ppm)
RCPActual.RegioRoomRH	R,4	33		Room humidity (RH)
RCPActual.RegioByPassRunMin	I,4	34		Time left in ByPass mode (min)
Alarms.AlaModStat	X,4	35		Worst alarm status in controller
AlaData.AlaPt1_Status	X,4	36		Presence alarm status: 0 = Not used 1 = Normal 2 = Blocked 3 = Acknowledge 4 = Not used 5 = Cancelled 6 = Not used 7 = Alarm
AlaData.AlaPt2_Status	X,4	37		Open window alarm status
AlaData.AlaPt3_Status	X,4	38		Condensation alarm status
AlaData.AlaPt4_Status	X,4	39		Room temp high alarm status
AlaData.AlaPt5_Status	X,4	40		Room temp low alarm status
AlaData.AlaPt6_Status	X,4	41		Room temp deviation alarm status
AlaData.AlaPt7_Status	X,4	42		Room controller in manual mode alarm status
AlaData.AlaPt8_Status	X,4	43		Sensor alarm status
Not used	-	44		
Not used	-	45		
Not used	-	46		
Not used	-	47		
Not used	-	48		

Signal name	Type	Modbus address	Default value	Description
Not used	-	49		
Not used	-	50		
Not used	-	51		
Not used	-	52		
Not used		53		
RCPActual.RegioVAVOutput	R,4	54		VAV damper output (0...100 %)
RCPActual.ECFanOutput	R,4	55	-	Output for EC fan (0...100 %)

Holding Register

Signal name	Type	Modbus address	Default value	Description
RCPInternal.RegioNotUsedX	X,3	1	-	Not used
RC_SetP_X.RegioFreeCoolAvailable	X,3	2	0	Sequence order for Cooling and Forced ventilation/VAV Damper: 0=Cooling activates before Forced ventilation/VAV Damper 1=Forced ventilation/VAV Damper activates before Cooling
RCPSettings.RegioHeatOutputSelect	X,3	3	2	Manual/Auto heat output
RCPSettings.RegioCoolOutputSelect	X,3	4	2	Manual/Auto cool output
RCPSettings.RegioFanSelect	X,3	5	4	Select fan mode: 0 = Off 1 = Manual speed 1 2 = Manual speed 2 3 = Manual speed 3 4 = Auto (5 = Auto 2) (only room unit with select (6 = Auto 1) button)
RC_Setp_X.RegioFanControlMode	X,3	6	3	Select fan control: 0 = No control 1 = The fan is controlled on heating demand 2 = The fan is controlled on cooling demand 3 = The fan is controlled by both heating and cooling demand
RCPSettings.RegioFanSpeed1Start	X,3	7	20	Controller output signal in % for fan speed 1 on heating or cooling control
RCPSettings.RegioFanSpeed2Start	X,3	8	60	Controller output signal in % for fan speed 2 on heating or cooling control
RCPSettings.RegioFanSpeed3Start	X,3	9	100	Controller output signal in % for fan speed 3 on heating or cooling control
RCPSettings.RegioFanSpeedHyst	X,3	10	5	Controller output hysteresis start/stopp fan speed.

Signal name	Type	Modbus address	Default value	Description
RCPSettings.RegioFanSpeedMax	X,3	11	3	Number of fan speeds (1-3)
RCPSettings.RegioForcedVentSelect	X,3	12	2	Manuell/Auto control of forced ventilation (0=Off, 1=On, 2=Auto)
RCPSettings.RegioChangeOverSelect	X,3	13	2	Manuell/Auto control of change-over (0=Heating, 1=Cooling, 2=Auto)
RCPSettings.RegioRemoteState	X,3	14	5	Is used for remote control unit state: 0 = Off 1 = Unoccupied 2 = Stand-by 3 = Occupied 5 = No remote control
RCPSettings.RegioUnitReturnState	X,3	15	3	Preset operating mode: 0=Off 1=Unoccupied 2=Stand-by 3=Occupied. Forced ventilation is not set in Occupied mode
RCPSettings.RegioUnitShutDownState	X,3	16	1	Shutdown mode: 0 = Off 1 = Unoccupied
RCPSettings.RegioBtnOnOffTime	X,3	17	5	Time (in sec) that the Occupancy button must be held depressed before Shutdown mode.
RCPSettings.RegioControllerMode	X,3	18	3	Control mode: 0 = Heating 1 = Heating/Heating 2 = Heating or cooling via the change-over function 3 = Heating/Cooling 4 = Heating/Cooling with VAV-control and forced supply air function 5 = Heating/Cooling with VAV-control 6 = Cooling 7 = Cooling/Cooling 8 = Heating /Cooling/VAV (RCP200xx-models) 9 = Heating/Heating or Cooling via change-over (RCP100F, RCP200xx)
RCPSettings.RegioCVHeatType	X,3	19	0	Actuator type heating: 0 = 0...10 V 1 = 2...10 V 2 = 10...2 V 3 = 10...0 V
RCPSettings.RegioCVCoolType	X,3	20	0	Actuator type cooling
RCPSettings.RegioCVVAVType	X,3	21	0	Actuator type VAV
RCPInternal.RegioNotUsedX	X,3	22	-	Not used
RCPSettings.RegioAi(0)	X,3	23	-	Not used

Signal name	Type	Modbus address	Default value	Description
RCPSettings.RegioAi1	X,3	24	0	Connected signal on AI1: 0 = Not used 1 = Room temperature 2 = Change-over temperature 3 = Outdoor temperature 4 = Condensation 5 = CO ₂ in room 6 = RH in room
RCPSettings.RegioAi2	X,3	25	2	Connected signal on AI2
RCPSettings.RegioDi(0)	X,3	26	-	Not used
RCPSettings.RegioDi1	X,3	27	3	Connected signal on DI1: 0 = Not used 1 = Open window 2 = Condensation alarm 3 = Presence 4 = Change-over
RCPSettings.RegioDi2	X,3	28	2	Connected signal on DI2
RCPSettings.RegioDi3	X,3	29	0	Connected signal on DI3
RCPSettings.RegioCi	X,3	30	2	Connected signal on CI
RCPSettings.RegioAo(0)	X,3	31	-	Not used
RCPSettings.RegioAo1	X,3	32	1	Connected signal on AO1: 0 = Not used 1 = Control valve heating 2 = Control valve cooling 3 = VAV damper 4 = EC-control
RCPSettings.RegioAo2	X,3	33	2	Connected signal on AO2
RCPSettings.RegioDo(0)	X,3	34	-	Not used
RCPSettings.RegioDo1	X,3	35	1	Connected signal on DO1: 0 = Not used 1 = Fan speed 1 2 = Fan speed 2 3 = Fan speed 3 4 = Forced ventilation 5 = Control valve heating pulse prop. 6 = Control valve cooling pulse prop. 7 = Control valve heating increase 8 = Control valve heating decrease 9 = Control valve cooling increase 10 = Control valve cooling decrease 11 = Lighting 12 = Jalusi In 13 = Jalusi Out 14 = Sum alarm 15 = Sum alarm A 16 = Sum alarm B
RCPSettings.RegioDo2	X,3	36	2	Connected signal on DO2
RCPSettings.RegioDo3	X,3	37	3	Connected signal on DO3
RCPSettings.RegioDo4	X,3	38	4	Connected signal on DO4
RCPSettings.RegioDo5	X,3	39	0	Connected signal on DO5
RCPSettings.RegioDo6	X,3	40	5	Connected signal on DO6
RCPSettings.RegioDo7	X,3	41	6	Connected signal on DO7

Signal name	Type	Modbus address	Default value	Description
RCPInternal.RegioNotUsedX	X,3	42	-	Not used
RCPInternal.RegioNotUsedX	X,3	43	-	Not used
RCPSettings.RegioModbusSlaveAddr	X,3	44		Modbus slave address
RCPSettings.RegioModbusParity	X,3	45	2	Modbus parity bit: 0 = No parity bit 1 = Odd parity bit 2 = Even parity bit
RCPInternal.RegioNotUsedX	X,3	46	-	Not used
RCPInternal.RegioNotUsedX	X,3	47	-	Not used
RCPSettings.RegioDispBacklightLO	X,3	48	20	Display lighting low (0...255)
RCPSettings.RegioDispBacklightHi	X,3	49	100	Display lighting high (0...255)
RCPSettings.RegioDispContrast	X,3	50	15	Contrast (0...15)
RCPSettings.RegioDisplayViewMode	X,3	51	0	Select viewmode for the display: 0 = Room temp 1 = Heat setpoint 2 = Cool setpoint 3 = Average cool/heat setpoint 4 = Only setpoint offset
RCPInternal.RegioNotUsedX	X,3	52	-	Not used
RCPSettings.RegioVAVOutputSelect	X,3	53	2	Manual/Auto heat output: 0 = Off 1 = Manual output 2 = Automatic output
RCPInternal.RegioNotUsedX	X,3	54	-	Not used
RCPInternal.RegioNotUsedX	X,3	55	-	Not used
RCPSettings.RegioBypassTime	I,3	56	120 min	Time in Bypass mode (min)
RCPSettings.RegioPresenceOffTime	I,3	57	10 min	Off delay for changing to no presence (min)
RCPSettings.RegioPresenceOnTime	I,3	58	0 min	On delay for changing to presence (min)
RCPSettings.RegioCVHeatPeriodTime	I,3	59	60 sec	Period time if pulse prop. control valves heating (sec)
RCPSettings.RegioCVCoolPeriodTime	I,3	60	60 sec	Period time if pulse prop. control valves cooling (sec)
RCPSettings.RegioCVHeatRunTime	I,3	61	120 sec	Run time close to open valve heating (sec)
RCPSettings.RegioCVCoolRunTime	I,3	62	120 sec	Run time close to open valve cooling (sec)
RCPInternal.RegioNotUsedX	X,3	63	-	Not used
RCPInternal.RegioNotUsedX	X,3	64	-	Not used
RCPInternal.RegioNotUsedX	X,3	65	-	Not used
RCPInternal.RegioNotUsedX	X,3	66	-	Not used
RCPInternal.RegioNotUsedX	X,3	67	-	Not used
RCPSettings.RegioOccSetPHeat	R,3	68	22 °C	Basic heating setpoint
RCPSettings.RegioOccSetPCool	R,3	69	24 °C	Basic cooling setpoint
RCPSettings.RegioStandbySetPDeadBand	R,3	70	3 °C	Deadband in Standby mode
RCPSettings.RegioUnOccSetPHeat	R,3	71	15 °C	Heating setpoint in Unoccupied mode
RCPSettings.RegioUnOccSetPCool	R,3	72	30 °C	Cooling setpoint in Unoccupied mode

Signal name	Type	Modbus address	Default value	Description
RCPSettings.RegioFrostSetP	R,3	73	8 °C	Frost protection setpoint
RCPSettings.RegioSetpointOffsetPos	R,3	74	3 °C	Max setpoint adjustment pos
RCPSettings.RegioSetpointOffsetNeg	R,3	75	3 °C	Max setpoint adjustment neg
RCPSettings.RegioSetPOffset	R,3	76	0 °C	Setpoint adjustment
RCPSettings.RegioPIDPGain	R,3	77	10 °C	Room controller P-band
RCPSettings.RegioPIDITime	R,3	78	300 sec	Room controller I-time
RCPSettings.RegioCVDeadband	R,3	79	2 %	Deadband control valve
RCPSettings.RegioAIChangeOverDiffHeat	R,3	80	3K	The difference between the temperature in the room and the media temperature for change-over to cooling
RCPSettings.RegioAIChangeOverDiffCool	R,3	81	4K	The difference between the temperature in the room and the media temperature for change-over to heating
RCPSettings.RegioAi1Comp	R,3	82	0 °C	Analog input 1 compensation
RCPSettings.RegioAi2Comp	R,3	83	0 °C	Analog input 2 compensation
RCPSettings.RegioInternalTempComp	R,3	84	0 °C	Internal room sensor compensation
RCPSettings.RegioTempFilterFactor	R,3	85	0.2°C	Filter factor for temperature on analogue input 0 = No filter 1 = Max filter
RCPSettings.RegioMinFlow	R,3	86	20 %	Min flow of cool output at Occupied when control state "Heat/Cool with VAV-control" or "Heat/Cool/VAV" is configured
RCPSettings.RegioMaxFlowHeat	R,3	87	80 %	Max flow of cool output when control state "Heat/Cool with VAV-control" is configured and heating is controlling the cool output
RCPIInternal.RegioNotUsedX	X,3	88	-	Not used
RCPIInternal.RegioNotUsedX	X,3	89	-	Not used
RCPIInternal.RegioNotUsedX	X,3	90	-	Not used
RCPIInternal.RegioNotUsedX	X,3	91	-	Not used
RCPIInternal.RegioNotUsedX	X,3	92	-	Not used
RCPSettings.RegioVAVOutputManual	R,3	93	0 %	Manual value VAV output (0...100 %)
RCPSettings.RegioHeatOutputManual	R,3	94	0 %	Manual value heat output (0...100%)
RCPSettings.RegioCoolOutputManual	R,3	95	0 %	Manual value cool output (0...100%)
RCPSettings.RegioRoomTempRemote	R,3	96	-255	Room temp. set by remote control if external room sensor is configured (-255 = disabled)
RCPIInternal.RegioNotUsedX	X,3	97	-	Not used
RCPIInternal.RegioNotUsedX	X,3	98	-	Not used
RCPIInternal.RegioNotUsedX	X,3	99	-	Not used
RCPSettings.RegioCVHeatExerciseDay	X,3	100	8	Day for exercise of heating actuator: 0 = Never 1-7 = Mon-Sun 8 = Every day
RCPSettings.RegioCVCoolExerciseDay	X,3	101	8	Day for exercise of cooling actuator
RCPSettings.RegioCVHeatExerciseHour	X,3	102	15	Hour for exercise of heating actuator
RCPSettings.RegioCVCoolExerciseHour	X,3	103	15	Hour for exercise of cooling actuator

Signal name	Type	Modbus address	Default value	Description
RCPSettings.RegioCVHeatExerciseMin	X,3	104	0	Minute for exercise of heating actuator
RCPSettings.RegioCVCoolExerciseMin	X,3	105	0	Minute for exercise of cooling actuator
RCPSettings.RegioALarmCategory(1)	X,3	106	3	Alarm category for presence: 0 = A alarm 1 = B alarm 2 = C alarm 3 = Event 4 = Disabled
RCPSettings.RegioALarmCategory(2)	X,3	107	3	Alarm category for open window
RCPSettings.RegioALarmCategory(3)	X,3	108	0	Alarm category for condensation
RCPSettings.RegioALarmCategory(4)	X,3	109	0	Alarm category for room temp high
RCPSettings.RegioALarmCategory(5)	X,3	110	0	Alarm category for room temp low
RCPSettings.RegioALarmCategory(6)	X,3	111	0	Alarm category for room temp deviation
RCPSettings.RegioALarmCategory(7)	X,3	112	2	Alarm category for room controller in manual mode
RCPSettings.RegioALarmCategory(8)	X,3	113	0	Alarm category for sensor alarm
RCPSettings.RegioAlarmActive	X,3	114	0	Activate alarm and events function for EXOscada: 0 = Not active 1 = Only alarm 2 = Only events 3 = Alarm and events is active
RCPSettings.RegioLightFunction	X,3	115	0	Select lighting control function: 0 = Manual control 1 = Time control 2 = Presence control 3 = Time or presence control
RCPSettings.RegioLightSelect	X,3	116	2	Manual/Auto control of the lighting: 0 = Off 1 = Manual On 2 = Auto
RCPSettings.RegioJalusiRunTime	I,3	117	240 sec	Run time for controlling the blinds in/out (sec)
RCPSettings.RegioCond_0V	R,4	118	0 %	Condensation at 0 volt input
RCPSettings.RegioCond_10V	R,4	119	100 %	Condensation at 10 volt input
RCPSettings.RegioCO2_0V	R,4	120	0ppm	CO2 at 0 V input signal
RCPSettings.RegioCO2_10V	R,4	121	1000ppm	CO2 at 10 V input signal
RCPSettings.RegioRH_0V	R,4	122	0 RH	RH at 0 V input signal
RCPSettings.RegioRH_10V	R,4	123	100 RH	RH at 10 V input signal
RCPSettings.RegioCondFilterFactor	R,4	124	0.2	Filter factor for condensation on analog input: 0 = No filter 1 = Max filter
RCPSettings.RegioCO2FilterFactor	R,4	125	0.2	Filter factor for CO2 on analog input: 0 = No filter 1 = Max filter
RCPSettings.RegioRHFilterFactor	R,4	126	0.2	Filter factor for RH on analogue input: 0 = No filter 1 = Max filter
RCPSettings.RegioAlarmHyst	R,4	127	0.2°C	Alarm hysteresis

Signal name	Type	Modbus address	Default value	Description
RCPSettings.RegioRoomTempHigh	R,4	128	40°C	High room temp
RCPSettings.RegioRoomTempLow	R,4	129	15°C	Low room temp
RCPSettings.RegioMaxDevRoom	R,4	130	20°C	Max allowed difference between setpoint and room temp before alarm
RCPSettings.RegioCondensationLimit	R,4	131	80 %	High limit for condensation alarm
RCPSettings.RegioCondensationHyst	R,4	132	2 %	Condensation alarm hysteresis
RCPSettings.RegioCO2PresenceLimit	R,4	133	800	Activate presence if CO2 is higher
RCPSettings.RegioCO2PresenceHyst	R,4	134	160	Diff for deactivate presence on CO2
RCPIInternal.RegioNotUsedX	X,3	135	-	Not used
RCPSettings.RegioDigOut1Select	X,3	136	2	Manual/Auto digital output 1: 0 = Manual off 1 = Manual on 2 = Auto
RCPSettings.RegioDigOut2Select	X,3	137	2	Manual/Auto digital output 2
RCPSettings.RegioDigOut3Select	X,3	138	2	Manual/Auto digital output 3
RCPSettings.RegioDigOut4Select	X,3	139	2	Manual/Auto digital output 4
RCPSettings.RegioDigOut5Select	X,3	140	2	Manual/Auto digital output 5
RCPSettings.RegioDigOut6Select	X,3	141	2	Manual/Auto digital output 6
RCPSettings.RegioDigOut7Select	X,3	142	2	Manual/Auto digital output 7
RCPSettings.RegioAnaOut1Select	X,3	143	2	Manual/Auto analogue output 1
RCPSettings.RegioAnaOut2Select	X,3	144	2	Manual/Auto analogue output 2
RCPSettings.RegioAnaOut1Manual	R,3	145	0	Manual value AO1
RCPSettings.RegioAnaOut2Manual	R,3	146	0	Manual value AO2
RCPSettings.RegioCO2LimitLow	R,4	147	600 ppm	Min. limit for the VAV damper when using CO ₂ control (min. = 0, max. = 9990 ppm)
RCPSettings.RegioCO2LimitHigh	R,4	148	800 ppm	Max. limit for the VAV damper when using CO ₂ control (min. = 0, max. = 9990 ppm)
Qsystem.PLA	X,3	149	FS	PLA address of module
Qsystem.ELA	X,3	150	FS	ELA address of module
RCPIInternal.RegioNotUsedX	X,3	151	-	Not used
RCPIInternal.RegioNotUsedX	X,3	152	-	Not used
RCPIInternal.RegioNotUsedX	X,3	153	-	Not used
RCPIInternal.RegioNotUsedX	X,3	154	-	Not used
TimeDp.Posts(0).T1	R,3	155	0	Start time per 1 Monday Occupied (HH.MM)
TimeDp.Posts(0).T2	R,3	156	0	Stop time per 1 Monday Occupied
TimeDp.Posts(0).T3	R,3	157	0	Start time per 2 Monday Occupied
TimeDp.Posts(0).T4	R,3	158	0	Stop time per 2 Monday Occupied
TimeDp.Posts(1).T1	R,3	159	0	Start time per 1 Tuesday Occupied
TimeDp.Posts(1).T2	R,3	160	0	Stop time per 1 Tuesday Occupied
TimeDp.Posts(1).T3	R,3	161	0	Start time per 2 Tuesday Occupied
TimeDp.Posts(1).T4	R,3	162	0	Stop time per 2 Tuesday Occupied
TimeDp.Posts(2).T1	R,3	163	0	Start time per 1 Wednesday Occupied

Signal name	Type	Modbus address	Default value	Description
TimeDp.Posts(2).T2	R,3	164	0	Stop time per 1 Wednesday Occupied
TimeDp.Posts(2).T3	R,3	165	0	Start time per 2 Wednesday Occupied
TimeDp.Posts(2).T4	R,3	166	0	Stop time per 2 Wednesday Occupied
TimeDp.Posts(3).T1	R,3	167	0	Start time per 1 Thursday Occupied
TimeDp.Posts(3).T2	R,3	168	0	Stop time per 1 Thursday Occupied
TimeDp.Posts(3).T3	R,3	169	0	Start time per 2 Thursday Occupied
TimeDp.Posts(3).T4	R,3	170	0	Stop time per 2 Thursday Occupied
TimeDp.Posts(4).T1	R,3	171	0	Start time per 1 Friday Occupied
TimeDp.Posts(4).T2	R,3	172	0	Stop time per 1 Friday Occupied
TimeDp.Posts(4).T3	R,3	173	0	Start time per 2 Friday Occupied
TimeDp.Posts(4).T4	R,3	174	0	Stop time per 2 Friday Occupied
TimeDp.Posts(5).T1	R,3	175	0	Start time per 1 Saturday Occupied
TimeDp.Posts(5).T2	R,3	176	0	Stop time per 1 Saturday Occupied
TimeDp.Posts(5).T3	R,3	177	0	Start time per 2 Saturday Occupied
TimeDp.Posts(5).T4	R,3	178	0	Stop time per 2 Saturday Occupied
TimeDp.Posts(6).T1	R,3	179	0	Start time per 1 Sunday Occupied
TimeDp.Posts(6).T2	R,3	180	0	Stop time per 1 Sunday Occupied
TimeDp.Posts(6).T3	R,3	181	0	Start time per 2 Sunday Occupied
TimeDp.Posts(6).T4	R,3	182	0	Stop time per 2 Sunday Occupied
TimeDp.Posts(7).T1	R,3	183	0	Start time per 1 holiday Occupied
TimeDp.Posts(7).T2	R,3	184	0	Stop time per 1 holiday Occupied
TimeDp.Posts(7).T3	R,3	185	0	Start time per 2 holiday Occupied
TimeDp.Posts(7).T4	R,3	186	0	Stop time per 2 holiday Occupied
TimeDp.Posts(8).T1	R,3	187	0	Start time per 1 Monday Unoccupied (HH.MM)
TimeDp.Posts(8).T2	R,3	188	0	Stop time per 1 Monday Unoccupied
TimeDp.Posts(8).T3	R,3	189	0	Start time per 2 Monday Unoccupied
TimeDp.Posts(8).T4	R,3	190	0	Stop time per 2 Monday Unoccupied
TimeDp.Posts(9).T1	R,3	191	0	Start time per 1 Tuesday Unoccupied
TimeDp.Posts(9).T2	R,3	192	0	Stop time per 1 Tuesday Unoccupied
TimeDp.Posts(9).T3	R,3	193	0	Start time per 2 Tuesday Unoccupied
TimeDp.Posts(9).T4	R,3	194	0	Stop time per 2 Tuesday Unoccupied
TimeDp.Posts(10).T1	R,3	195	0	Start time per 1 Wednesday Unoccupied
TimeDp.Posts(10).T2	R,3	196	0	Stop time per 1 Wednesday Unoccupied
TimeDp.Posts(10).T3	R,3	197	0	Start time per 2 Wednesday Unoccupied
TimeDp.Posts(10).T4	R,3	198	0	Stop time per 2 Wednesday Unoccupied
TimeDp.Posts(11).T1	R,3	199	0	Start time per 1 Thursday Unoccupied
TimeDp.Posts(11).T2	R,3	200	0	Stop time per 1 Thursday Unoccupied
TimeDp.Posts(11).T3	R,3	201	0	Start time per 2 Thursday Unoccupied
TimeDp.Posts(11).T4	R,3	202	0	Stop time per 2 Thursday Unoccupied
TimeDp.Posts(12).T1	R,3	203	0	Start time per 1 Friday Unoccupied
TimeDp.Posts(12).T2	R,3	204	0	Stop time per 1 Friday Unoccupied
TimeDp.Posts(12).T3	R,3	205	0	Start time per 2 Friday Unoccupied

Signal name	Type	Modbus address	Default value	Description
TimeDp.Posts(12).T4	R,3	206	0	Stop time per 2 Friday Unoccupied
TimeDp.Posts(13).T1	R,3	207	0	Start time per 1 Saturday Unoccupied
TimeDp.Posts(13).T2	R,3	208	0	Stop time per 1 Saturday Unoccupied
TimeDp.Posts(13).T3	R,3	209	0	Start time per 2 Saturday Unoccupied
TimeDp.Posts(13).T4	R,3	210	0	Stop time per 2 Saturday Unoccupied
TimeDp.Posts(14).T1	R,3	211	0	Start time per 1 Sunday Unoccupied
TimeDp.Posts(14).T2	R,3	212	0	Stop time per 1 Sunday Unoccupied
TimeDp.Posts(14).T3	R,3	213	0	Start time per 2 Sunday Unoccupied
TimeDp.Posts(14).T4	R,3	214	0	Stop time per 2 Sunday Unoccupied
TimeDp.Posts(15).T1	R,3	215	0	Start time per 1 holiday Unoccupied
TimeDp.Posts(15).T2	R,3	216	0	Stop time per 1 holiday Unoccupied
TimeDp.Posts(15).T3	R,3	217	0	Start time per 2 holiday Unoccupied
TimeDp.Posts(15).T4	R,3	218	0	Stop time per 2 holiday Unoccupied
TimeDp.Posts(16).T1	R,3	219	0	Start time per 1 Monday Lighting (HH.MM)
TimeDp.Posts(16).T2	R,3	220	0	Stop time per 1 Monday Lighting
TimeDp.Posts(16).T3	R,3	221	0	Start time per 2 Monday Lighting
TimeDp.Posts(16).T4	R,3	222	0	Stop time per 2 Monday Lighting
TimeDp.Posts(17).T1	R,3	223	0	Start time per 1 Tuesday Lighting
TimeDp.Posts(17).T2	R,3	224	0	Stop time per 1 Tuesday Lighting
TimeDp.Posts(17).T3	R,3	225	0	Start time per 2 Tuesday Lighting
TimeDp.Posts(17).T4	R,3	226	0	Stop time per 2 Tuesday Lighting
TimeDp.Posts(18).T1	R,3	227	0	Start time per 1 Wednesday Lighting
TimeDp.Posts(18).T2	R,3	228	0	Stop time per 1 Wednesday Lighting
TimeDp.Posts(18).T3	R,3	229	0	Start time per 2 Wednesday Lighting
TimeDp.Posts(18).T4	R,3	230	0	Stop time per 2 Wednesday Lighting
TimeDp.Posts(19).T1	R,3	231	0	Start time per 1 Thursday Lighting
TimeDp.Posts(19).T2	R,3	232	0	Stop time per 1 Thursday Lighting
TimeDp.Posts(19).T3	R,3	233	0	Start time per 2 Thursday Lighting
TimeDp.Posts(19).T4	R,3	234	0	Stop time per 2 Thursday Lighting
TimeDp.Posts(20).T1	R,3	235	0	Start time per 1 Friday Lighting
TimeDp.Posts(20).T2	R,3	236	0	Stop time per 1 Friday Lighting
TimeDp.Posts(20).T3	R,3	237	0	Start time per 2 Friday Lighting
TimeDp.Posts(20).T4	R,3	238	0	Stop time per 2 Friday Lighting
TimeDp.Posts(21).T1	R,3	239	0	Start time per 1 Saturday Lighting
TimeDp.Posts(21).T2	R,3	240	0	Stop time per 1 Saturday Lighting
TimeDp.Posts(21).T3	R,3	241	0	Start time per 2 Saturday Lighting
TimeDp.Posts(21).T4	R,3	242	0	Stop time per 2 Saturday Lighting
TimeDp.Posts(22).T1	R,3	243	0	Start time per 1 Sunday Lighting
TimeDp.Posts(22).T2	R,3	244	0	Stop time per 1 Sunday Lighting
TimeDp.Posts(22).T3	R,3	245	0	Start time per 2 Sunday Lighting
TimeDp.Posts(22).T4	R,3	246	0	Stop time per 2 Sunday Lighting
TimeDp.Posts(23).T1	R,3	247	0	Start time per 1 holiday Lighting

Signal name	Type	Modbus address	Default value	Description
TimeDp.Posts(23).T2	R,3	248	0	Stop time per 1 holiday Lighting
TimeDp.Posts(23).T3	R,3	249	0	Start time per 2 holiday Lighting
TimeDp.Posts(23).T4	R,3	250	0	Stop time per 2 holiday Lighting
TimeHp.Posts(0).FromDate	R,3	251	01.01	Start date holiday period 1 (MM.DD)
TimeHp.Posts(0).ToDate	R,3	252	01.01	Stop date holiday period 1 (MM.DD)
TimeHp.Posts(1).FromDate	R,3	253	01.01	Start date holiday period 2 (MM.DD)
TimeHp.Posts(1).ToDate	R,3	254	01.01	Stop date holiday period 2 (MM.DD)
TimeHp.Posts(2).FromDate	R,3	255	01.01	Start date holiday period 3 (MM.DD)
TimeHp.Posts(2).ToDate	R,3	256	01.01	Stop date holiday period 3 (MM.DD)
TimeHp.Posts(3).FromDate	R,3	257	01.01	Start date holiday period 4 (MM.DD)
TimeHp.Posts(3).ToDate	R,3	258	01.01	Stop date holiday period 4 (MM.DD)
TimeHp.Posts(4).FromDate	R,3	259	01.01	Start date holiday period 5 (MM.DD)
TimeHp.Posts(4).ToDate	R,3	260	01.01	Stop date holiday period 5 (MM.DD)
TimeHp.Posts(5).FromDate	R,3	261	01.01	Start date holiday period 6 (MM.DD)
TimeHp.Posts(5).ToDate	R,3	262	01.01	Stop date holiday period 6 (MM.DD)
TimeHp.Posts(6).FromDate	R,3	263	01.01	Start date holiday period 7 (MM.DD)
TimeHp.Posts(6).ToDate	R,3	264	01.01	Stop date holiday period 7 (MM.DD)
TimeHp.Posts(7).FromDate	R,3	265	01.01	Start date holiday period 8 (MM.DD)
TimeHp.Posts(7).ToDate	R,3	266	01.01	Stop date holiday period 8 (MM.DD)
TimeHp.Posts(8).FromDate	R,3	267	01.01	Start date holiday period 9 (MM.DD)
TimeHp.Posts(8).ToDate	R,3	268	01.01	Stop date holiday period 9 (MM.DD)
TimeHp.Posts(9).FromDate	R,3	269	01.01	Start date holiday period 10 (MM.DD)
TimeHp.Posts(9).ToDate	R,3	270	01.01	Stop date holiday period 10 (MM.DD)
Alarms.AlaAcknow	X,3	271	255	External alarms are acknowledged by setting this signal to the alarm number that you want to acknowledge
Alarms.AlaBlock	X,3	272	255	External alarms are blocked by setting this signal to the alarm number that you want to block
Alarms.AlaUnBlock	X,3	273	255	External alarms are unblocked by setting this signal to the alarm number that you want to unblock
QSystem.Sek	X,3	274	-	Real-time clock: Second 0-59
QSystem.Minute	X,3	275	-	Real-time clock: Minute 0-59
QSystem.Hour	X,3	276	-	Real-time clock: Hour 0-23
QSystem.WDay	X,3	277	-	Real-time clock: Weekday 1-7, 1=Monday
QSystem.Week	X,3	278	-	Real-time clock: Week number 1-53
QSystem.Date	X,3	279	-	Real-time clock: Day of the month 1-31
QSystem.Month	X,3	280	-	Real-time clock: Month 1-12
QSystem.Year	X,3	281	-	Real-time clock: Year 0-99
RCPSettings.RegioMinECFanSpeed	R,3	282	1 V	Min. limit for EC fan (%)
RCPSettings.RegioMaxECFanSpeed	R,3	283	10 V	Max. limit for EC fan (%)
RCPSettings.RegioMinHeat	R,3	284	0 %	Min. limit for the heat output

Signal name	Type	Modbus address	Default value	Description
RCPSettings.RegioMinFlowStandby	R,3	285	10 %	Min flow of cool output at Standby when control state “Heat/Cool with VAV-control” or “Heat/Cool/VAV” is configured
RCPSettings.RegioMinFlowUnoccupied	R,3	286	10 %	Min. flow of cool output at Unoccupied when control state “Heat/Cool with VAV-control” or “Heat/Cool/VAV” is configured
RCPSettings.RegioMinFlowOff	R,3	287	0 %	Min. flow of cool output at Off when control state “Heat/Cool with VAV-control” or “Heat/Cool/VAV” is configured
RCPSettings.ForcedVentHysteresis	R,3	288	1°C	The hysteresis that is used when forced ventilation is activated and free cool is active, i.e. forced ventilation damper is opened prior to the cooling signal.

Chapter 18 LonWorks network variables

Name	Type	Description
Configuration		
nciSndHrtBt	SNVT_time_sec	Pulse (0=disabled)
nciRcvHrtBt	SNVT_time_sec	Max. time before a requested value is discarded
nciSetPnts	SNVT_temp_setpt	Setpoints
nciHvacType	SNVT_hvac_type	Model
nciBypassTime	SNVT_time_min	Time in bypass mode
nciCO2PresenceHyst	SNVT_ppm	Hysteresis for inactivation of occupancy
nciCO2PresLimit	SNVT_ppm	CO ₂ concentration at which occupancy is activated
nciCO2LimitLow	SNVT_ppm	CO ₂ concentration at which the dampers start to open
nciCO2LimitHigh	SNVT_ppm	CO ₂ concentration at which the dampers are completely open
nciPpmHyst	SNVT_ppm	Hysteresis before ppm values are transmitted via the bus
nciTempHyst	SNVT_temp_p	Hysteresis before temperature values are transmitted via the bus
nciPercentHyst	SNVT_lev_percent	Hysteresis before percentages are transmitted via the bus
Inputs (nvi)		
nviSpaceTemp	SNVT_temp_p	Room temperature
nviSetPtOffset	SNVT_temp_p	Setpoint offset
nviOccManCmd	SNVT_occupancy	Setting of running mode, Occ/UnOcc/By/Standby
nviOccSensor	SNVT_occupancy	Signal from an occupancy detector On/Off
nviHeatCool	SNVT_hvac_mode	Change-over
nviEnergyHoldOff	SNVT_switch	Open window
nviSourceTemp	SNVT_temp_p	AI change-over
nviOutdoorTemp	SNVT_temp_p	Outdoor temperature
nviSpaceRH	SNVT_lev_percent	Relative humidity in the room
nviSpaceIAQ	SNVT_ppm	CO ₂ concentration in the room
nviCondenseSens	SNVT_percent	Condensation detector
nviCondenseGuard	SNVT_switch	Condensation detector On/Off

Outputs (nvo)		
nvoSpaceTemp	SNVT_temp_p	Room temperature
nvoUnitStatus	SNVT_hvac_status	Running mode, controller
nvoEffectSetPt	SNVT_temp_p	PID setpoint
nvoEffectOccup	SNVT_occupancy	Running mode, Regio unit
nvoHeatCool	SNVT_hvac_mode	Running mode, heating/cooling
nvoFanSpeed	SNVT_switch	Current fan speed
nvoTerminalLoad	SNVT_lev_percent	Total output signal
nvoHeatPrimary	SNVT_lev_percent	Output heating
nvoCoolPrimary	SNVT_lev_percent	Output cooling
nvoSpaceRH	SNVT_lev_percent	Relative humidity in the room
nvoOutdoorTemp	SNVT_temp_p	Outdoor temperature
nvoSpaceCO2	SNVT_ppm	CO ₂ concentration in the room
nvoEnergyHoldOff	SNVT_switch	Open window
nvoCondenseSens	SNVT_lev_percent	Condensation detector
nvoLightControl	SNVT_switch	Lighting On/Off
nvoLJalousieIn	SNVT_switch	Blind in
nvoJalousieOut	SNVT_switch	Blind out
nvoAlarm	SNVT_state	Alarm
nvoVAVPrimary	SNVT_lev_percent	Output VAV damper (Y3)
nvoECFanPrimary	SNVT_lev_percent	Output EC fan

Index

+

+C 14

A

About the manual 6
 More information 6
 Terms 6
Accessories for Regio Maxi 15
Activation of the different operating modes 62
Actuators 68
 Exercise 58
 Thermal actuators 68
 Three-point actuators 68
AI 14
Analogue inputs 14
Analogue outputs 14
AO 14
Application examples 9
Applications 7
Auto control 59

B

Basic models 11
Basic setpoint 66
Battery 14
Battery backup 14
Bypass 62

C

Calculation of the active setpoint 66
Central control 64
Change-over function 56
Changing the battery 80
CI 14
Communication 8
Communication port 14
 Port 1 14
 TCP/IP port 14
Communication ports 14
Condensation input 14
Configuration 18
Control modes 50
 Cooling 52
 Cooling/Cooling 52
 Heating 50
 Heating or cooling via the change-over function 51
 Heating/Cooling 51
 Heating/Cooling with VAV-control 51
 Heating/Cooling with VAV-control and forced supply air function 51

Heating/Heating 50
Control of blinds 58
Cooling 52
Cooling/Cooling 52

D

DI 14
Digital inputs 14
Digital outputs 14
Dipswitches 19
Display handling 69
 Indications 69
DO 14

E

Exercise 58

F

Fan control 59
 Auto control 59
 Manual control 59
 Off/Unoccupied 60
 Select button 59

G

GDO 14

H

Heating 50
Heating or cooling via the change-over function 51
Heating/Cooling 51
Heating/Cooling with VAV-control and forced supply air function 51
Heating/Heating 50
Humidity sensor 58

I

Indications 69, 78
 Communication 78
 Occupancy button 78
Inputs 14
 Analogue 14
 Condensation 14
 Digital 14
Installation 20
 preparations 18

Introduction to Regio Maxi 7

L

Labels 18
Lighting control 58
Local time control 64
LON communication 8

M

Maintenance and service 80
Manual control 59
Models 10
More information 6
Mounting 7, 20

O

Occupancy button 62, 64, 78
Occupancy detector 63, 65
Occupied 62
Occupied/Bypass 67
Off 61, 66
Off/Unoccupied 60
Operating modes 61
Operating modes
 Occupied 62
Outdoor temperature sensor 58
Outputs
 24 V DC 14
 Analogue 14
 Digital MosFet 14
 Digital relays 14
 GDO (24 V AC) 14

P

Parameter menu 70
Port 1 14
Preset operating mode 62

R

Relay outputs 14
Remove the cover 81
Resetting the application memory 81
RU-DOS 11
RU-F-models 11

S

Select button 59, 70
Setpoint calculation 66
 Calculation of the active setpoint 66
Setpoint displacement 66
Shutdown 63
Special input CI 56
Split output signal 50, 52
Stand-by 61, 67
SW1-4 19

T

TCP/IP port 14
Technical data 13
Terms 6
Thermal actuators 68
Three-point actuators 68

U

Unoccupied 61, 66

V,W

Wiring 22
Wiring for RCP100 / RCP100T / RCP100L 24
Wiring for RCP100F / RCP100FT / RCP100FL 30
Wiring for RCP200 / RCP200T / RCP200L 36
Wiring for RCP200F / RCP200FT / RCP200FL 42
Wiring for RU-... 23

REGIN - THE CHALLENGER IN BUILDING AUTOMATION

AB Regin

Head office

Box 116, S-428 22 Källered,
Sweden

Phone: +46 31 720 02 00

Fax: +46 31 720 02 50

info@regin.se

www.regincontrols.com



THE CHALLENGER IN BUILDING AUTOMATION