

## IT Regolatore ambiente Serie TH

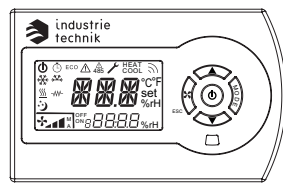

### Caratteristiche tecniche

<b>Alimentazione:</b>	110...230 Vca ±10%, 50/60 Hz
<b>Potenza assorbita:</b>	max 1,3W
<b>Temperatura di funzionamento:</b>	0...50°C
<b>Visualizzazione:</b>	Display LCD con retroilluminazione
<b>Ingressi:</b>	2 contatti liberi da potenziale 2 o 3 sonde NTC10-02 porta USB per configurazione parametri e aggiornamento software
<b>Uscite:</b>	3 uscite analogiche 0...10V (R <sub>L</sub> > 10K) a seconda del modello 5 relè SPST 230 Vca, 3A (AC1) a seconda del modello
<b>Comunicazione:</b>	Modbus RTU (Slave) a seconda del modello
<b>Campo di lettura temperatura:</b>	-15...90°C
<b>Dimensioni:</b>	128 x 80 x 55.5 mm
<b>Installazione:</b>	Scatola da incasso 3 moduli
<b>Classe di protezione:</b>	IP30, classe II
<b>Norme conformità CE:</b>	EN 60730-1/A16:2007, EN 60730-2-9:2003, EN 61000-6-3:2007, EN 61000-6-1:2007

## EN Room controller Series TH

### Technical features

<b>Power:</b>	110...230 Vac ±10%, 50/60 Hz
<b>Power consumption:</b>	max 1,3W
<b>Operating temperature:</b>	0...50°C
<b>Display:</b>	backlit LCD display
<b>Inputs:</b>	2 potential free contacts 2 or 3 NTC10-02 sensors USB port for configuration and software updates
<b>Outputs:</b>	3 analogue outputs 0...10V (R <sub>L</sub> > 10K) depending on model 5 SPST relays, 230 V AC, 3A (AC1) depending on model
<b>Communications:</b>	Modbus RTU (Slave) depending on model
<b>Temperature reading range:</b>	-15...90°C
<b>Dimensions:</b>	128 x 80 x 55.5 mm
<b>Installation:</b>	3 module flush-mounted box
<b>Protection class:</b>	IP30, class II
<b>CE standard conformity:</b>	EN 60730-1/A16:2007, EN 60730-2-9:2003, EN 61000-6-3:2007, EN 61000-6-1:2007

## DE Raumregler Serie TH

### Technische Eigenschaften

<b>Stromversorgung:</b>	110...230 Vca ±10%, 50/60 Hz
<b>Aufgenommene Leistung:</b>	max 1,3W
<b>Betriebstemperatur:</b>	0...50°C
<b>Anzeige:</b>	LCD-Display mit Hintergrundbeleuchtung
<b>Eingänge:</b>	2 potenzialfreie Kontakte 2 oder 3 NTC10-02-Fühler USB-Anschluss zur Parameterkonfiguration und Software-Aktualisierung
<b>Ausgänge:</b>	3 Analogausgänge 0...10V (R <sub>L</sub> > 10K) je nach Modell 5 SPST-Relais 230 Vca, 3A (AC1) je nach Modell
<b>Kommunikation:</b>	RTU-Modbus (Slave) je nach Modell
<b>Temperaturlesebereich:</b>	-15...90°C
<b>Abmessungen:</b>	128 x 80 x 55.5 mm
<b>Installation:</b>	Einbaudose 3 Module
<b>Schutzklasse:</b>	IP30, Klasse II
<b>EG-Konformitätsnormen:</b>	EN 60730-1/A16:2007, EN 60730-2-9:2003, EN 61000-6-3:2007, EN 61000-6-1:2007

## FR Régulateur d'ambiance Série TH

### Caractéristiques techniques

<b>Alimentation:</b>	110...230 Vca ±10%, 50/60 Hz
<b>Puissance absorbée:</b>	maxi 1,3W
<b>Température de fonctionnement:</b>	0...50°C
<b>Affichage:</b>	Écran LCD avec rétro-éclairage
<b>Entrées:</b>	2 contacts libres de potentiel 2 ou 3 sondes NTC10-02 Port USB pour la configuration de paramètres et la mise à jour du logiciel
<b>Sorties:</b>	3 sorties analogiques 0...10 V (R <sub>L</sub> > 10 K) selon le modèle 5 relais SPST 230 Vca, 3 A (AC1) selon le modèle
<b>Communication:</b>	Modbus RTU (Esclave) selon le modèle
<b>Plage de lecture de la température:</b>	-15...90°C
<b>Dimensions:</b>	128 x 80 x 55.5 mm
<b>Installation:</b>	Boîtier à encastrement 3 modules
<b>Classe de protection:</b>	IP30, classe II
<b>Normes de conformité CE:</b>	EN 60730-1/A16:2007, EN 60730-2-9:2003, EN 61000-6-3:2007, EN 61000-6-1:2007

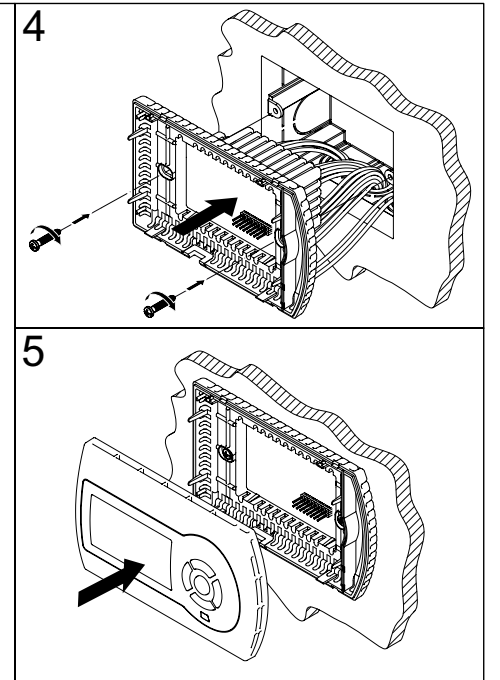
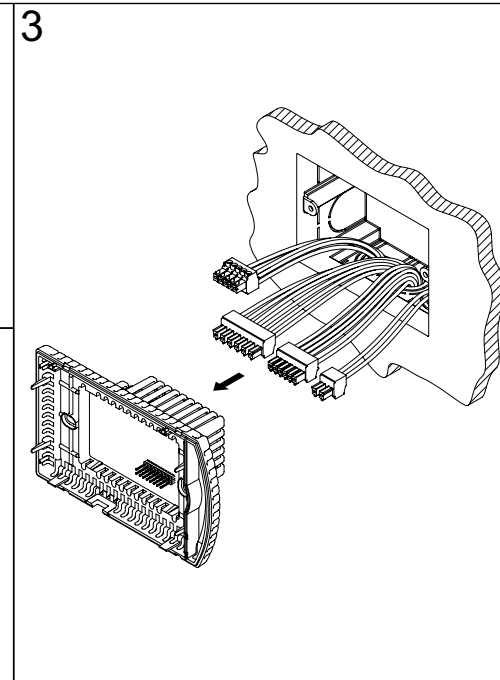
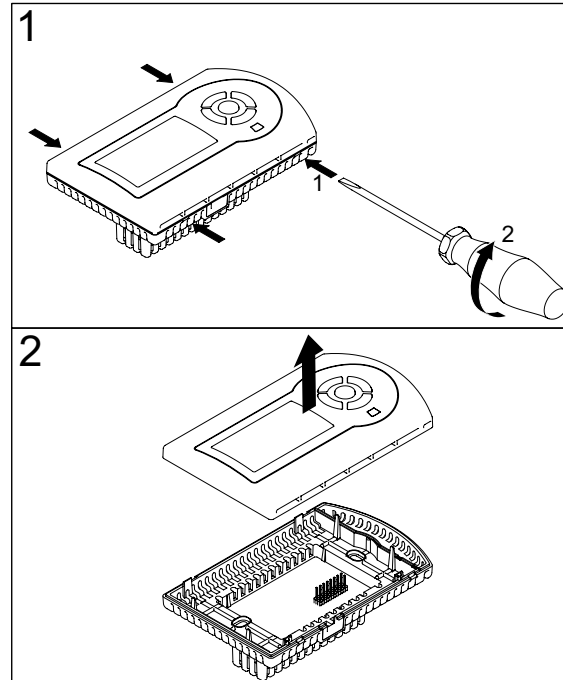
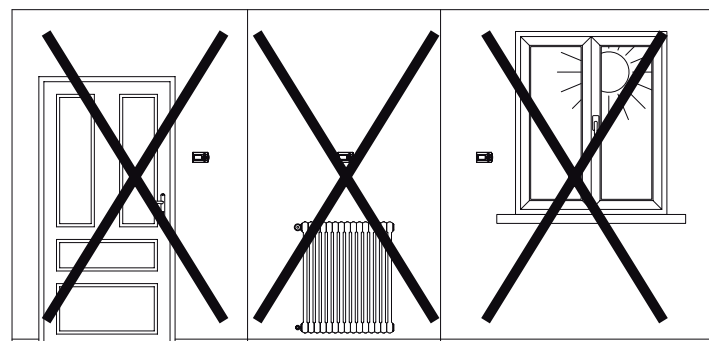
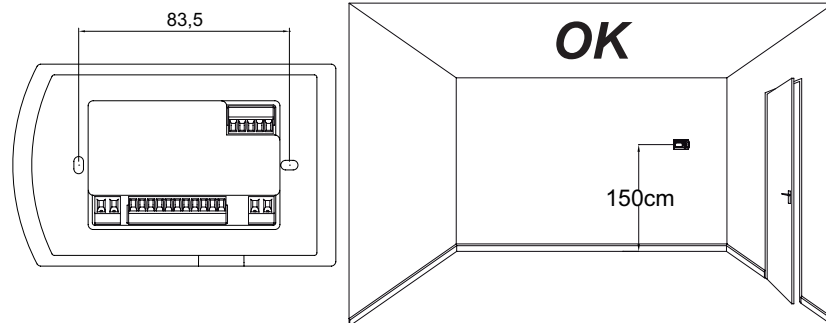
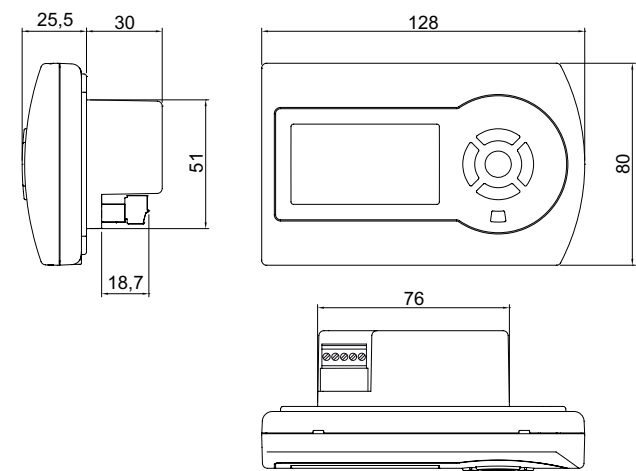

**IT** - Le operazioni di installazione e manutenzione devono essere eseguite da personale qualificato e in assenza di alimentazione dell'apparecchio e dei carichi esterni. Industrietechnik non risponderà di eventuali danni causati da inadeguata installazione e/o dalla manomissione o rimozione dei dispositivi di sicurezza.

**EN** - Each single operation done on the unit, either installation or maintenance, must be done without main supply on the unit and external loads. Such operations are permitted only by skilled workers. Industrietechnik is not responsible for possible damages caused by an inadequate installation and/or by removed or exchanged security devices.

**DE** - Die Installation und die Wartung, darf nur im spannungsfreiem Zustand von qualifizierten Fachleuten durchgeführt werden. Industrietechnik übernimmt keine Haftung für Schäden, die durch unsachgemäße Verwendung, falsche Installation oder durch Entfernung von Sicherheitsvorrichtungen verursacht werden.

**FR** - Pendant les opérations de montage et de maintenance mettre l'appareil ainsi que les charges connectées à celui-ci hors tension. Toutes ces opérations doivent être effectuées par un technicien qualifié. Industrietechnik ne pourra être tenu pour responsable des dommages causés suite à une mauvaise installation et/ou une maintenance manipulant ou enlevant les dispositifs de sécurité.

TH-0xxSx1

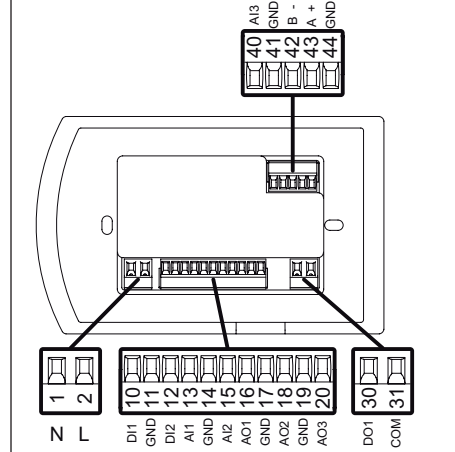

TH-1xxSx1

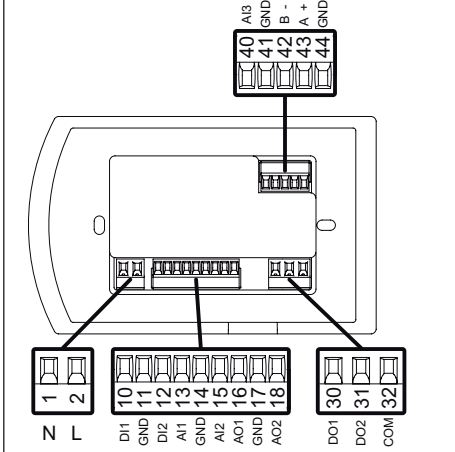

TH-2xxSx1

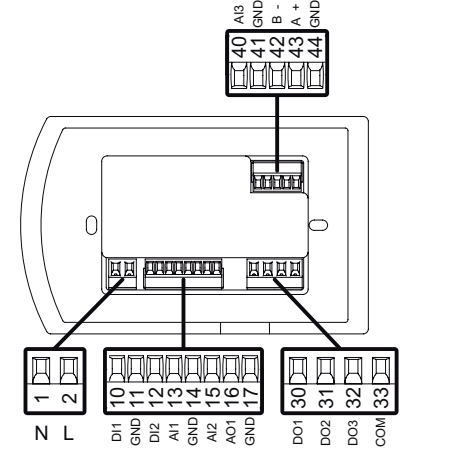

TH-3xxSx1

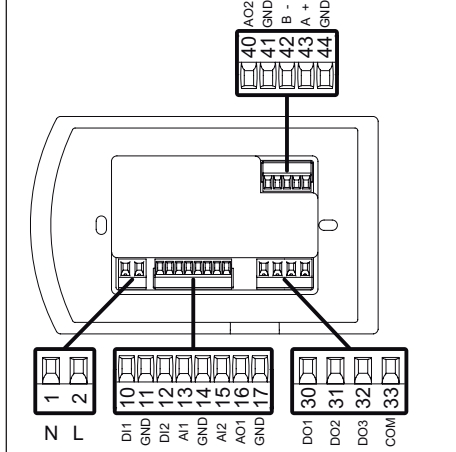

TH-4xxSx1

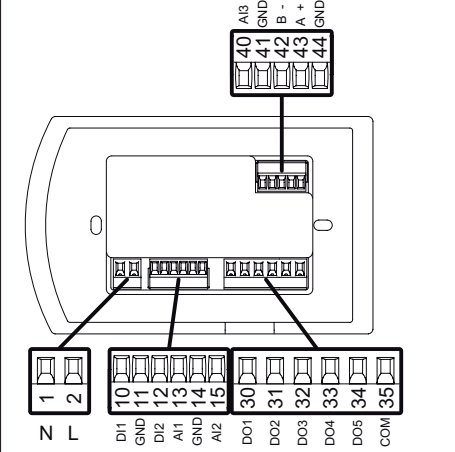

È possibile scaricare il manuale d'uso completo all'indirizzo web:  
[www.industrietechnik.it](http://www.industrietechnik.it)  
Con riserva di modifiche tecniche senza preavviso.

It is possible to download the complete user's manual at the web address:  
[www.industrietechnik.it](http://www.industrietechnik.it)  
Subject to change without notice.

Das komplette Handbuch kann unter folgenden Link heruntergeladen werden:  
[www.industrietechnik.it](http://www.industrietechnik.it)  
Technische Änderungen vorbehalten.

Il est possible de télécharger le manuel d'utilisation complet à l'adresse web:  
[www.industrietechnik.it](http://www.industrietechnik.it)  
Sous réserve de modifications sans préavis.

**IT - Tipo di funzionamento (vedi schemi di collegamento elettrico):**

- MOD 1 = 0 Riscaldamento
- MOD 1 = 1 Riscaldamento/riscaldamento (2 stadi)
- MOD 1 = 2,12 Riscaldamento/raffreddamento con cambio stagione automatico (2 tubi)
- MOD 1 = 3,13 Riscaldamento/raffreddamento con cambio stagione tramite contatto remoto (2 tubi)
- MOD 1 = 4,14 Riscaldamento/raffreddamento con cambio stagione tramite parametro (2 tubi)
- MOD 1 = 5 Riscaldamento + resistenza elettrica/raffreddamento, con cambio stagione automatico (2 tubi + resistenza elettrica)
- MOD 1 = 6 Riscaldamento + resistenza elettrica/raffreddamento, con cambio stagione tramite contatto remoto (2 tubi)
- MOD 1 = 7 Riscaldamento + resistenza elettrica/raffreddamento, con cambio stagione tramite parametro (2 tubi)
- MOD 1 = 8 Riscaldamento/Raffreddamento (4 tubi)
- MOD 1 = 9 Riscaldamento + resistenza elettrica/raffreddamento (4 tubi + resistenza elettrica)
- MOD 1 = 10 Raffreddamento
- MOD 1 = 11 Raffreddamento/raffreddamento (2 stadi)

**EN - Operating mode (see electrical wiring diagrams):**

- MOD 1 = 0 Heating
- MOD 1 = 1 Heating/heating (2 stages)
- MOD 1 = 2,12 Heating/cooling mode with automatic season changeover (2 pipe)
- MOD 1 = 3,13 Heating/cooling mode with season changeover by contact (2 pipe)
- MOD 1 = 4,14 Heating/cooling mode with season changeover by parameter (2 pipe)
- MOD 1 = 5 Heating + electric resistance/cooling, mode with automatic season changeover (2 pipe + electric resistance)
- MOD 1 = 6 Heating + electric resistance/cooling, mode with season changeover by contact (2 pipe)
- MOD 1 = 7 Heating + electric resistance/cooling, mode with season changeover by parameter (2 pipe)
- MOD 1 = 8 Heating/cooling (4 pipe)
- MOD 1 = 9 Heating + electric resistance/cooling (4 pipe + electric resistance)
- MOD 1 = 10 Cooling
- MOD 1 = 11 Cooling/cooling (2 stages)

**DE - Betriebsart (Siehe Elektrisches Schema):**

- MOD 1 = 0 Heiz
- MOD 1 = 1 Heiz/Heiz (2-Stufig)
- MOD 1 = 2,12 Heiz/Kühlbetrieb Elektrischem Widerstand mit automatischem Jahreszeitenwechsel (2 Rohr)
- MOD 1 = 3,13 Heiz/Kühlbetrieb Elektrischem Widerstand mit Jahreszeitenwechsel von Kontakt (2 Rohr)
- MOD 1 = 4,14 Heiz/Kühlbetrieb Elektrischem Widerstand mit Jahreszeitenwechsel von Parameter (2 Rohr)
- MOD 1 = 5 Heiz + Elektrischem Widerstand/Kühlbetrieb mit automatischem Jahreszeitenwechsel (2 Rohr + Elektrischem Widerstand)
- MOD 1 = 6 Heiz + Elektrischem Widerstand/Kühlbetrieb mit Jahreszeitenwechsel von Kontakt (2 Rohr)
- MOD 1 = 7 Heiz + Elektrischem Widerstand/Kühlbetrieb mit Jahreszeitenwechsel von Parameter (2 Rohr)
- MOD 1 = 8 Heiz/Kühlbetrieb (4 Rohr)
- MOD 1 = 9 Heiz + Elektrischem Widerstand/Kühlbetrieb (4 Rohr + Elektrischem Widerstand)
- MOD 1 = 10 Kühlbetrieb
- MOD 1 = 11 Kühlbetrieb/Kühlbetrieb (2-Stufig)

**FR - Type de fonctionnent (voir schéma électrique):**

- MOD 1 = 0 Chauffage
- MOD 1 = 1 Chauffage/refroidissement (2 étages)
- MOD 1 = 2,12 Chauffage/refroidissement avec changement de saison automatique (2 tubes)
- MOD 1 = 3,13 Chauffage/refroidissement avec changement de saison par contact (2 tubes)
- MOD 1 = 4,14 Chauffage/refroidissement avec changement de saison par paramètre (2 tubes)
- MOD 1 = 5 Chauffage + résistance électrique/refroidissement, avec changement de saison automatique (2 tubes + résistance électrique)
- MOD 1 = 6 Chauffage + résistance électrique/refroidissement, avec changement de saison par contact (2 tubes)
- MOD 1 = 7 Chauffage + résistance électrique/refroidissement, avec changement de saison par paramètre (2 tubes)
- MOD 1 = 8 Chauffage/refroidissement (4 tubes)
- MOD 1 = 9 Chauffage + résistance électrique/refroidissement (4 tubes + résistance électrique)
- MOD 1 = 10 Refroidissement
- MOD 1 = 11 Refroidissement/refroidissement (2 étages)

